



J.S.

FEDERATION INTERNATIONALE DE L'AUTOMOBILE

ANNUAIRE DU SPORT AUTOMOBILE

YEAR BOOK OF AUTOMOBILE SPORT

1981

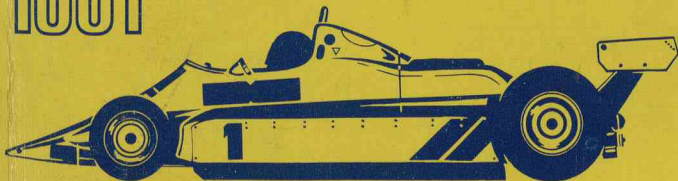



Annexe "J" au Code Sportif International 1981

Classification, définition et spécifications des voitures

Appendix "J" to the International Sporting Code 1981

Classification, definition and specifications of cars

Anhang "J" zum Internationalen Automobil-Sportgesetz 1981

Einteilung, Begriffsbestimmungen und Erläuterungen der Fahrzeuge

Allegato "J" al Codice Sportivo Internazionale 1981

Classificazione, definizione e caratteristiche delle vetture

In the case of differences of interpretation as regards the terms used in the various translations of official FISA regulations, only the French text will be considered authentic. (Exception: Art 274—see page 221, article 15.)
 Any amendments will be published in the monthly FISA Motor Sport Bulletin.

Appendix "J" to the International Sporting Code 1981

Classification, definition and specification of cars

Contents

	Pages
TITLE 1—CLASSIFICATIONS OF CARS	109
Art 251—Categories and groups	109
TITLE 2—DEFINITIONS	109
Art 252—Definitions	109
TITLE 3—SAFETY PRESCRIPTIONS	123
Art 253—Safety devices for all cars competing in events entered on the FIA International Calendar	123
TITLE 4—GENERAL PRESCRIPTIONS	147
Art 254—Rule for changing from one group to another and authorised amalgamation of groups	147
Art 255—Prescriptions common to all cars of Groups 1 to 6	147
SERIES-PRODUCTION TOURING CARS (Group 1)	161
Art 256—Definition	161
Art 257—Minimum production and number of seats	161
Art 258—Modifications authorised	161
TOURING CARS (Group 2)	171
Art 259—Definition	171
Art 260—Minimum production and number of seats	171
Art 261—Modifications authorised	171
SERIES-PRODUCTION GRAND TOURING CARS (Group 3)	183
Art 262—Definition	183
Art 263—Minimum production and number of seats	183
Art 264—Modifications authorised	183
GRAND TOURING CARS (Group 4)	183
Art 265—Definition	183
Art 266—Minimum production and number of seats	183
Art 267—Modifications authorised	185

	Pages
SPECIAL PRODUCTION CARS (Group 5)	185
Art 268—Definition	185
Art 269—Modifications allowed	185
TWO-SEATER RACING CARS (Group 6)	191
Art 270—Definition	191
Art 271—General specifications	191
Art 272—Supplementary specifications	191
SPORTS CARS (Group 5/75—Group 6/79)	197
Art 270a—Definition	197
Art 271a—General specifications	197
Art 272a—Supplementary specifications	197
SINGLE-SEATER RACING CARS (Groups 7 and 8)	201
Art 274—International Formula No 1	201
Art 275—International Formula No 2/No 3	223
Art 277—Formule Libre racing cars (Group 8)	245
TITLE 5—NATIONAL FORMULAE	247

TITLE 1—CLASSIFICATIONS OF CARS

Art 251—Categories and groups: Cars competing in events shall be distributed into the following categories and groups:

Category A: Recognised production cars (numbers between brackets are those of the required minimum production in 12 consecutive months, except in Group 4 where the period of production is 24 consecutive months).

Group 1: series-production touring cars (5,000)

Group 2: touring cars (1,000)

Group 3: series-production grand touring cars (1,000)

Group 4: grand touring cars (400)

Group 5: special production cars deriving from Groups 1 to 4

Category B:

Group 6: two-seater racing cars

Group 7: international formula racing cars

Group 8: 'formule libre' racing cars

TITLE 2—DEFINITIONS

Art 252—Definitions:

a) Recognised production cars: Cars of which the series-production of a certain number (see Art 251) of identical (see definition of this word hereafter) cars has been completed within a certain period of time, and which are meant for the normal sale (see over) to the individual purchaser.

b) Racing cars: Cars manufactured solely for speed races on a circuit or a closed course. These cars are generally defined by the international racing formulae, the specifications of which are fixed by the FIA for a certain period of time. Racing cars not being defined by any international formula are said to be 'formule libre' and prescriptions concerning them must be specified by the organiser and set out in the supplementary regulations of the event.

c) Identical cars: Cars belonging to the same fabrication series and which have the same coachwork (outside and inside), same mechanical components and same chassis (even though this chassis may be amalgamated with the coachwork in case of a unitary construction).

'Mechanical components' include all parts for the propulsion, suspension, steering and braking system and all accessories whether moving or not which are necessary for their normal functioning (such as, for instance, electric accessories).

(ca) **Chassis:** Structure of the car which holds mechanical components and coachwork together, and includes any structural part which is located below the horizontal plane passing through the centre of the wheel hubs.

(cb) **Model of car:** Car belonging to a production-series distinguishable by a specific conception and specific external general lines of the coachwork and by an identical mechanical conception of the engine and the transmission to the wheels.

A model of car may exist in several variants (for example, different power or engine cylinder-capacity), which may possibly be the subject of separate homologation.

d) Minimum production: This minimum production applies to cars which are identical, the manufacturing of which has been fully completed within the period defined by Art 251.

e) Normal sale: Means the distribution of cars to individual purchasers through the normal commercial channels of the manufacturer.

f) Homologation: is the official certification made by the FIA that a minimum number of cars of a specific model has been made on series-production terms to justify classification in Groups, 1, 2, 3 or 4 of these regulations. Application for homologation shall be submitted to the FIA by the ACN of the country in which the vehicle is manufactured and shall entail the drawing up of a homologation form (see below). It must be established in accordance with the special regulations called 'Regulations for homologation', laid down by the FIA, and a manufacturer wishing to obtain the homologation of his model(s) must undertake to abide by their prescriptions. Homologation will only be granted to car-models which were still in production on January 1st 1977 or the production of which was started after that date. Homologation of a series-produced car will become void 5 years after the date on which the series-production of the said model has been stopped.

Homologation of a model may only be valid for one group. The transferring of a previously recognised model from one group to another will therefore nullify the effect of the said previous homologation.

Definitive abandonment of the series-production: the series-production is considered as abandoned when the annual production decreases under 10% of the minimum production of the group considered.

g) Homologation forms: All cars recognised by the FIA shall be the subject

of a descriptive form called homologation form on which shall be entered all data enabling identification of the said model.

The production of the forms at scrutineering and/or at the start may be required by the promoters who will be entitled to refuse the participation of the entrant in the event in case of non-production.

In case of any doubt remaining after the checking of a model of car against its homologation form, the scrutineers would have to refer either to the maintenance booklet published for the use of the make's distributors or to the general catalogue in which are listed all spare parts.

In case of lack of enough accurate documentation, scrutineers may carry out direct scrutineering by comparison with an identical part available from a concessionnaire. It will rest with the competitor to obtain the recognition form and, if need be, the additional forms concerning his car, from the ACN of the manufacturing country of the vehicle, or from the FIA.

Whenever the scrutiny of a car shows the complete compliance of it with its homologation form, inasmuch as is required for the group in which it is admitted, there is no need to worry about its year of fabrication.

Therefore, the chassis and engine numbers which may be mentioned on the homologation form are not to be taken into consideration.

A) Description

Generally speaking, a form breaks down in the following way:

1) A basic form (12 or 15 pages according to the age of the car) giving a description of the basic model.

2) At a later stage, a certain number of additional sheets describing 'homologation extensions', which can be 'variants', or 'errata' or 'evolutions'.

a) Variants: These are either supply variants (two suppliers providing the same part for a driver and the client does not have the possibility of choice), or options (supplied on request and available at the concessionnaires).

b) Erratum: Replaces and cancels an incorrect piece of information previously supplied by the constructor on a form.

c) Evolution: Characterised by modifications made on a permanent basis to the basic model (complete cessation of the production of the car in its original form).

B) Use

The number on the basic homologation form of the vehicle indicates the group in which this car is homologated.

Group 1: Nrs between 5000—5999

Group 2: Nrs between 1000—1999

Group 3: Nrs between 3000—3999

Group 4: Nrs between 500—999

A vehicle homologated in Group 1 can race in Group 2.

A vehicle homologated in Group 3 can race in Group 4.

The extensions are identified by two numbers and a letter, E or V (ex. 8/5 V, 9/3 E).

The first number shows the order in which this extension has been recorded. The letter E shows whether it is a question of an evolution or an erratum. The letter V indicates a variant. The second number indicates the order in which the evolution or the variant has been recorded.

i) Formulae of equivalence between reciprocating piston engines and special engines:

Rotary piston engines: Cars with rotary piston engines covered by the NSU-Wankel patents will be admitted on the basis of a piston displacement equivalence. This equivalence is twice the volume determined by the difference between the maximum and minimum capacity of the working-chamber.

Turbine engines: Cars propelled by a turbine engine will be admitted on the basis of a formula of equivalence with regard to alternating piston engines. This formula is the following:

$$C = \frac{A ((3.10 \times R) - 7.63)}{0.09625}$$

A = High pressure nozzle area—expressed in square centimetres by which is meant the area of the air-flow at the exit from the stator blades (or at the exit from the first stage if the stator has several stages). Measurement is done by taking the minimum area between the fixed blades of the high pressure turbine first stage. In cases where the first stage turbine stator blades are adjustable, they will open to their greatest extent to present the greatest area for the determination of area 'A'.

The area of the high pressure nozzle is thus the product—expressed in square centimetres—of height by width and by the number of vane spaces.

C = Cylinder-capacity of reciprocating piston engine expressed in cubic centimetres.

R = The pressure ratio, ie, the ratio of the compressor of the turbine engine. This pressure ratio is obtained by multiplying together the value for each stage of the compressor, as indicated hereafter:

Subsonic axial compressor: 1.15 per stage

Trans-sonic axial compressor: 1.5 per stage

Radial compressor: 4.25 per stage

Thus a compressor with one radial and six axial stages will be designated to have a pressure of:

$$4.25 \times 1.15 \times 1.15 \times 1.15 \times 1.15 \times 1.15 \times 1.15 \text{ or } 4.25 \times 1.15^6$$

The FISA reserve their right to modify the basis of comparison established between conventional type engines and new type engines, while giving a previous notice of two years to start from 1st January, following the date on which the decision was made.

j) Coachwork: By coachwork is meant:

—externally: all parts of the car licked by the air-stream and situated above a plane passing through the centre of the wheel-hubs. (Single-seaters of Group 8: All parts of the car licked by the air stream.)

—internally: all visible parts of the passenger compartment.

The measurement of the bodywork in relation to the wheel-hubs plane will be made driver on board, whatever the conditions.

Coachworks are differentiated as follows:

- 1) completely closed coachworks,
- 2) completely open coachworks,
- 3) convertible coachworks: with a hood in either supple (drop-head) or rigid (hard-top) material.

k) Use of aerodynamic devices on cars of Groups 6 and 8: Shall definitely be considered as coachwork all external parts of the car which extend above the highest point of the wheels equipped with tyres with the exception of the roll-over bar and of components definitely associated with the functioning of the engine or transmission.

Any specific part of the car which has an aerodynamic influence on the stability of the vehicle must be mounted on the entirely sprung part of the car and shall be firmly fixed whilst the car is in motion.

l) Wheel: Flange and rim: by complete wheel is meant flange, rim and tyre.

Measuring wheel width: Measuring wheel width is to be done with the wheel mounted on the car, on the ground, the vehicle in race condition, driver aboard, at any point along the circumference of the tyre except in the area in contact with the ground.

In no case can the interior width of the rim where the bead joins the edge, exceed the overall width of the tyre. (For every Group except 7.)

m) Friction surface of the brakes: Surface swept by the linings on the drum, or the pads on both sides of the disc when the wheel achieves a complete revolution.

n) Cylinder block: The crankcase and the cylinders.

o) Manifolds:

Intake manifold: Part collecting the air-fuel mixture from the carburettor(s), and extending to the entrance ports of the cylinder head, in the case of a carburettor induction system, and the part collecting the air from the air intake control device and extending to the ports of the cylinder head, in the case of an injection intake system.

Exhaust manifold: Part collecting together the gases from the cylinder head and extending to the first gasket separating it from the rest of the exhaust system.

p) Starting: Compulsory starter with electrical or other source of energy carried aboard the car and able to be controlled by the driver when normally in his seat.

q) Reverse gear: All vehicles must have a gearbox including a reverse gear, which must be in working order when the car starts the events and able to be operated by the driver in his seat.

s) Ballast: It is permitted to complete the weight of the car by one or several ballasts incorporated to the materials of the car on condition that they are strong and unitary blocks, mounted by means of tools and providing for the possibility to fix seals if the scrutineers deem it necessary.

Removable ballast is not permitted.

A spare wheel may be used as ballast under the hereabove conditions.

Application: Cars of Groups 2, 4, 5, 6, 8.

No kind of ballast is authorised on cars of Groups 1 and 3.

In rallies however, the carrying of tools and spare parts for the car will be allowed under the conditions laid out in Art 253 a). Any object of a dangerous nature (battery, inflammable products, etc) must be carried outside the cockpit.

For cars of Groups 2 and 4, the eventually used ballast should be placed on the passenger's compartment floor, it should be visible and sealed.

t) Perimeter of the car seen from above: It is pointed out that it concerns

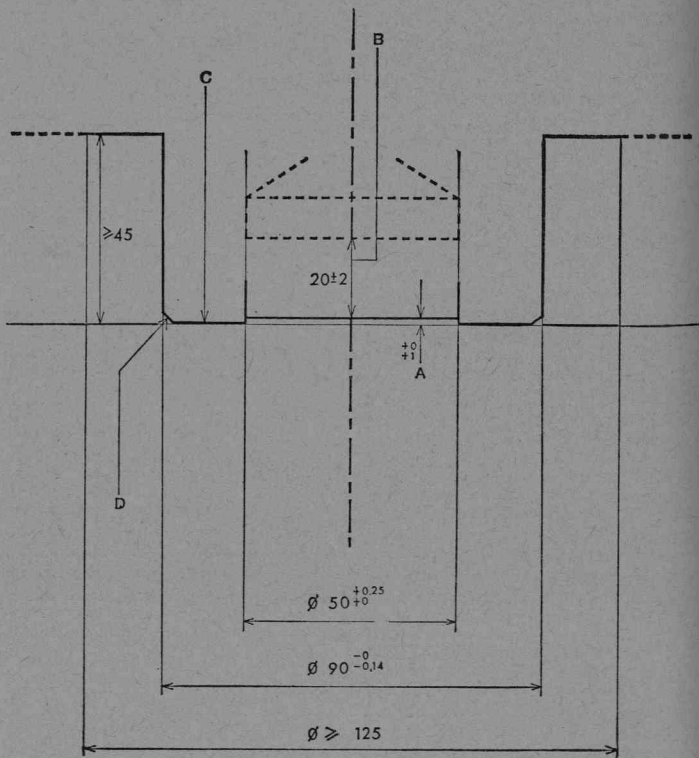

Dessin/drawing No 1

Orifice de remplissage standardisé pour voitures/Standardised car fuel filler

Alliage recommandé/Recommended material: AU4G
(aluminium, cuivre/copper, magnesium)

Usinage/Machining

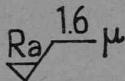

μ = Micron, Ra = Rugosité admise/average roughness of a surface.
Toutes cotes en mm/All dimensions in mm.

- A: Position du clapet au repos/position of the released valve.
Clapet normalement fermé et étanche à la pression de 100 m. bar (1.5 psi)/Valve normally shut and leak proof under 100 m. bar of pressure (1.5 psi).
- B: Ouverture du clapet/valve lift (20 ± 2 mm).
- C: Plan de joint; tolérance de surfaçage: 0.05 mm/Gasket facing plane, unswerving tolerance: 0.05 mm.
- D: Chanfrein $1+1$ à 45° ou arrondi (rayon 1 mm)/
+0
Bevel cut $1+1$ at 45° , or rounded at 1 mm radius.
+0

L'attention des fabricants de l'accoupleur (côté-stands) est attirée sur le fait que la partie en contact avec la surface C de l'orifice de remplissage doit être munie d'un joint Vitton. Aussi, il est recommandé de ne pas dépasser un guidage initial, avant l'ouverture des soupapes, de 18 mm, de telle sorte qu'à l'ouverture maximale autorisée de la soupape (22 mm) la pénétration totale ne dépasse pas 40 mm, laissant ainsi 5 mm minimum de tolérance.

The attention of the manufacturers of the coupling (pit-side) is drawn to the fact that the part in contact with the area C of the filler must be provided with a Vitton joint. It is advised not to exceed an initial locating penetration of 18 mm, before the opening of the valve, so that, with the valve open to the authorised maximum (22 mm), the total penetration does not exceed 40 mm, leaving thus a minimum of 5 mm tolerance.

the car such as presented on the starting grid, for event considered.

u) Refuelling procedure—Standardised coupling: In case of a centralised system provided by the circuit, or a system provided by the competitors, the refuelling hose shall be provided with a leak-proof coupling to fit the standardised filler mounted on the car. The dimensions of this filler are given in the diagram shown on page 110.

All cars must be provided with a fuel filler complying with the diagram shown on page 110. The leak-proof filler must comply with the dead man principle and must not therefore incorporate any retaining device when in an open position (spring-loaded, bayonet, etc).

The air-vent(s) must be equipped with non return valves and valves having the same closing system as that of the standard filler, and of the same diameter.

During refuelling the outlet of the air-vent must be connected with the appropriate coupling, either to the main supply-tank or to a transparent portable container with a minimum capacity of 20 litres provided with a closing system rendering it completely leak-proof. The venting catch tanks must be empty at the beginning of the refuelling procedure.

In the case where the circuits are unable to provide the entrants with a centralised system, these will have to refuel according to the above procedure. In no case the level of the reserve tank may exceed three metres above the track where the refuelling takes place, for all the duration of the event.

Application: Please refer to the General Prescriptions of the FIA Championships.

v) : Stock block engine

v1) : Maximum cylinder capacity: 5000 cm³.

v2) : Engine whose series production will have been checked by the FIA as being 5,000 units a year, and mounted on (a) series production car(s).

v3) : Engine with valves operated by rockers and pushrods.

v4) : Use of the original cylinder head. The number and location of the original camshaft(s) may not be changed. The number of valves may not be changed. The valve angle and the angle of the intake and exhaust ports may not be changed in relation to the cylinder axis.

v5) : Use of the original block. The number of main bearings may not be changed.

v6) : Supercharging prohibited.

TITLE 3—SAFETY PRESCRIPTIONS

Art 253—Safety devices for all cars competing in events entered on the FIA International Calendar

A car, the construction of which is deemed to be dangerous, may be excluded by the Stewards of the meeting.

If a device is optional, it must be fitted in a way that complies with regulations.

a) Supplementary locking devices. A supplementary locking device(s) for

engine bonnet, boot lid and other important objects carried on board of the vehicle (such as a spare-wheel, tool set, etc).

Application: Compulsory for cars of Groups 1, 2, 3, 4, 5.

b) Supplementary protection of the pipes: A supplementary protection of fuel pipes and brake lines outside the coachwork against any risk of damage (stones, corrosion, breaking of mechanical pieces, etc) and inside the cockpit against any risk of fire (fuel pipes only).

Application: Compulsory for cars of Groups 1, 2, 3, 4, 5 and 6. However, in Groups 1 to 4, if the series production fitting is kept, no additional protection will be necessary.

Cables, lines and electrical equipment : Except if the cables, lines and electrical equipment such as battery, fuel pump, etc, are in compliance with the requirements of the aircraft industry as regards their location, material and connections, they must be placed or fitted in such a way that any leakage cannot result in:

- Accumulation of liquid.
- Entry of liquid into the cockpit.
- Contact between liquid and any electrical line or equipment.

Should the cables, lines or electrical equipment pass through or be fitted in the cockpit, they must be fully enclosed in a cover of a liquid-tight and fire-proof material.

All fuel lines external to the cockpit, with the exception of fuel lines permanently mounted on the engine, should be a reinforced construction, attached by screw-on connectors. They must withstand a 70 kg/cm² pressure (1,000 psi) and a 230° C temperature.

All electrical wiring should be enclosed in a fire-proof material.

Application: Compulsory for cars of Groups 6, 8.

c) Safety belts: Wearing of one diagonal strap and one abdominal strap: fixation points on the shell: 3.

Application: Compulsory for all cars of Groups 1, 2, 3 and 4 participating in rallies.

Wearing of two shoulder straps and one abdominal strap: fixation points on the shell: two for the abdominal strap — two or eventually one symmetrical in relation to the seat for the shoulder straps.

Application: Compulsory for all cars of Groups 1, 2, 3 and 4 (except in rallies).

It is permitted to make a hole in a series-production seat to allow the passing of a safety belt.

Wearing of two shoulder straps, one abdominal strap and two straps between the legs: fixation points on the body; two for the abdominal strap, two or eventually one symmetrical in relation to the seat for the shoulder straps, two for the straps between the legs.

Application: Compulsory for all cars of Groups 5, 6 and 8.

d) Extinguishers—Extinguishing systems: They must have the following characteristics:

	Groups 1 to 4 (minimum quantities)	Groups 5 and 6 (system installed) (minimum quantities)
Rally	4 kg Halon 1211 or 1311, powder or equivalent* (in 2 bottles maximum)	
Circuit	4 kg Halon 1211 or 1301, powder or equivalent* (in 2 bottles maximum)	<i>Closed car</i> Passenger compartment 2.5 kg Engine compartment 5 kg <i>Open car</i> Passenger compartment 5 kg Engine compartment 2.5 kg Halon 1211 or 1301
Slalom	Idem as for circuit	Idem as for circuit
Hill Climbs	Idem as for circuit	Idem as for circuit
Autocross	1 kg Halon 1211 or 1301 or powder or equivalent* (in a single bottle)	1 kg Halon 1211 or 1301
Rallycross	Idem as for autocross	Idem as for autocross

*Equivalent: a product having an efficiency and non-toxicity at least equal to that of Halon (1211).

d1.1) Installation: Each extinguisher bottle must be installed in such a way that it is capable of withstanding accelerations of up to 25g no matter how these are applied.

d1.2) Operation Triggering:

—**Groups 1-4:** The extinguisher(s) must be easily accessible to the driver and co-driver.

—**NB:** In the case of an installed system, see hereinafter under Groups 5 and 6.

—**Groups 5-6**

The two systems must be triggered simultaneously.

Any triggering system is allowed. However a source of energy not coming from the main source must be provided in the case of a triggering system which is not exclusively mechanical.

The driver seated normally at his steering wheel with his safety harness attached must be able to trigger the system manually; the same applies to any person outside the car. The means of triggering from the exterior must be positioned close to the circuit breaker or combined with it, and must be marked by the letter "E" in a white circle of at least 10 cm diameter with a red edge.

Automatic triggering by heat sensors is recommended.

The system must work in any position, even when the car is upside down.

d1.3) Checking: The type of extinguishant, its quantity, and the total weight of the bottle must be specified on the bottle(s).

d2) Cars of Groups 1,2,3,4. (Circuit or Rally):

Cars of Groups 1 to 4 must be equipped with one or two bottles containing a minimum of 4 kg of the extinguishant Halon 1211 or 1301 (BCF-BTM), powder, or equivalent.

An extinguisher system as provided for in point d3 is allowed

d3) Cars of Groups 5 and 6 (Circuit):

Minimum capacities of extinguisher systems

- Closed cars: cockpit: 2.5 kg
 engine: 5 kg
- Open cars: cockpit: 5 kg
 engine: 2.5 kg

The extinguishant must be Halon 1211 or 1301 (BCF-BTM) only.

Extinguishing equipment must withstand fire and be protected against impacts.

The extinguisher system nozzles must be installed in such a way that they are not directly pointed at the driver (danger of burns caused by cold).

Discharge time: cockpit: 30 secs for Halon 1211, 60 secs for Halon 1301
 engine: 10 secs

d4) Group 8 cars: The extinguisher system for national Formulae is left up to the ASNs. However the directives laid down in d3 are strongly recommended.

e) Safety roll-bars:

General considerations

- 1) The basic purpose of such devices is to protect the driver if the car turns over or is involved in a serious accident. This purpose should always be borne in mind.
- 2) Whenever bolts and nuts are used, the bolts should be of a sufficient minimum diameter, according to the number used. They should be of the highest possible quality (preferably aircraft). Square head bolts and nuts should not be used.
- 3) One continuous length of tubing should be used for the main structure with smooth continuous bends and no evidence of crimping or wall failure.
- 4) All welding should be of the highest quality possible with full penetration (preferably arc welding and in particular heliarc). Although good outside appearance of a weld does not necessarily guarantee its quality, poor looking welds are never a sign of good workmanship.
- 5) Braces should preferably be of the same size tubing as used for the main structure.
Their fixation should be located as near as possible to the top of the roll bar, in any case at a minimum of $\frac{3}{4}$ of the total height of the roll bar.
- 6) For space-frame constructions it is important that crash-bar structures are attached to cars in such a way as to spread the loads over a wide area. It is not sufficient to simply attach the roll-bar to a single tube or junction of tubes. The roll-bar should be designed in such a way as to be an extension of the frame itself, not simply an attachment to the frame.
Considerable care should be attached to the necessary strengthening of the basic structure, for instance by adding reinforcement bars or plates so as to properly distribute the loads.
- 7) For monocoque constructions, consideration should be given to using a

Art 253: Safety devices

roll-bar hoop of 360 degrees completely around the inside of the car, and attached with suitable mounting plates. This type of roll-bar then becomes a substitute for the frame.

A) Closed cars:

As a general rule, the safety cage must be made of two main hoops, one behind the front seats and one following the windscreen pillars (see drawing No 2). For some groups of cars, (see hereunder) the windscreen hoop is not compulsory and the designing may be realised as shown in drawing No 3.

The safety roll-bar or cage must be conceived in such a way as not to obstruct the access to the front seats and not encroach on the space provided for the driver and the passenger. On the other hand, it is allowed that the elements of the roll-bar or cage encroach on the space of the rear passengers, and pass through the upholstery or the rear seat(s).

The main roll-bar hoop(s) must be placed as near as possible to the roof in order to limit its crushing in the event of a somersault.

In order to avoid an important deformation of the coachwork and consequently protect more efficiently the driver in case of a lateral impact, it is possible to enhance the efficiency of the safety roll-bar, thanks to the mounting of a longitudinal support at the door level.

The tube constituting this support should be integrated in the safety framework, the front and rear hoops of which it connects, and to which it is fitted, either by welding or with a removable coupling; it cannot be fixed on the coachwork itself.

Its diameter, its thickness and its material correspond to the specifications of the FIA for safety roll-bars. Its angle with the horizontal should not exceed 5° . It should divide the height of the opening of the door in the relation 2:1, ie, it is fitted on the framework at a height equal to 1/3rd of the total height of the door above the door sill.

B) Open cars:

Conception and realisation identical to those prescribed for closed cars. Moreover, the main hoop behind the front seats must be symmetrical about the lengthwise centre-line of the car and comply with the following figures (see drawing 10):

Height: The top of the roll-bar must be at least 5 cm (2 in) over the helmet of the driver normally sat at his wheel.

Width: Measured on the inside of the vertical struts of the roll-bar; there must be at least 20 cm (8 in) measured at 60 cm (23 in) above the driver's and passenger's seat (on the line perpendicular to the driver's vertebrae from the lengthwise centre-line to the outside).

Lengthwise location: The lengthwise distance between the top of the roll-bar and the helmet of the driver normally sitting at his steering wheel must not exceed 25 cm.

Will also be considered as open cars, cars which have no structural parts between the upper part of the windshield framework and that of the rear window, if any.

C) Attachment of roll-over bars on the body:

It is specified that roll-over bars must make use of two plates:

— a steel plate, welded, riveted, or bolted on to the chassis body shell, at least 2 mm thick, with a prolongation along a vertical component of the body (for instance, a door pillar: see drawing 4).

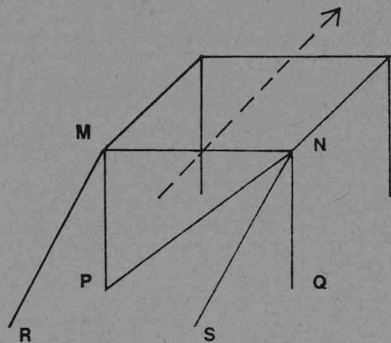

Dessin/drawing No 2

Groupes 1 à 5

Le montage d'un renfort diagonal est obligatoire. Les différentes variantes autorisées sont: MQ, MS, NP, NR. (NP est indiqué sur le dessin no 2 comme un exemple.)

Groups 1 to 5

Fitting of a diagonal strut is compulsory. The various authorised alternatives are: MQ, MS, NP, NR. (NP is shown on drawing 2 as an example.)

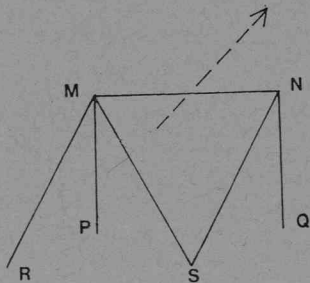

Dessin/drawing No 3

Groupes 1 à 4

Le montage d'un renfort diagonal est obligatoire. Les différentes variantes autorisées sont: MQ, MS, NP, NR. (MS est indiqué sur le dessin no 3 comme un exemple.)

Groups 1 to 4

Fitting of a diagonal strut is compulsory. The various authorised alternatives are: MQ, MS, NP, NR. (MS is shown on drawing 3 as an example.)

Montant de portière/ ▶
Door pillar

(par exemple/
for example)

Plancher/Floor

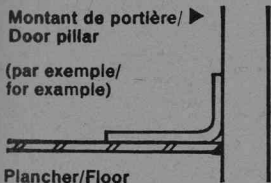

Dessin/drawing No 4

Dessin/drawing No 5

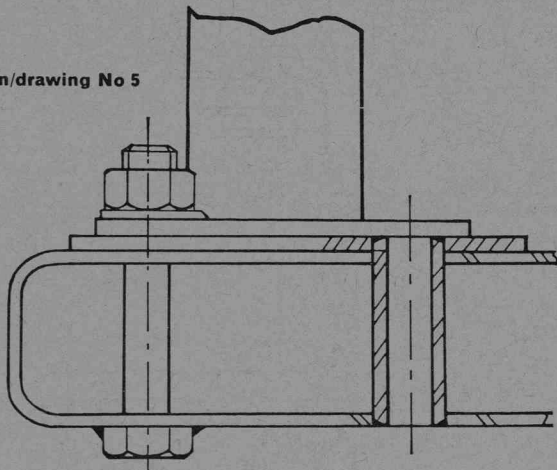

Dessin/drawing No 6

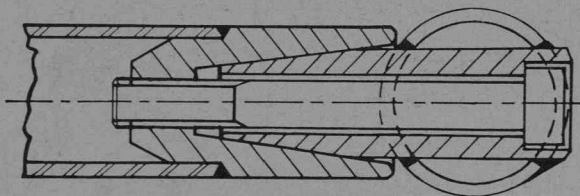

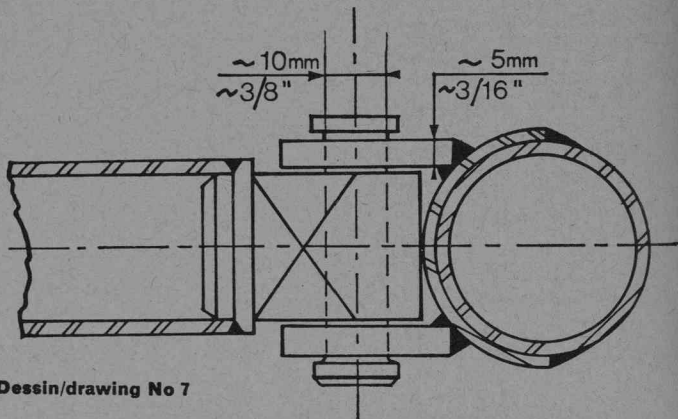

Dessin/drawing No 7

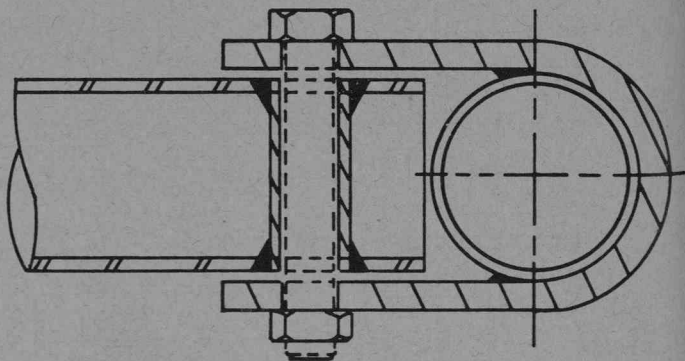

Dessin/drawing No 7a: En dehors de la structure principale/Outside the main structure.

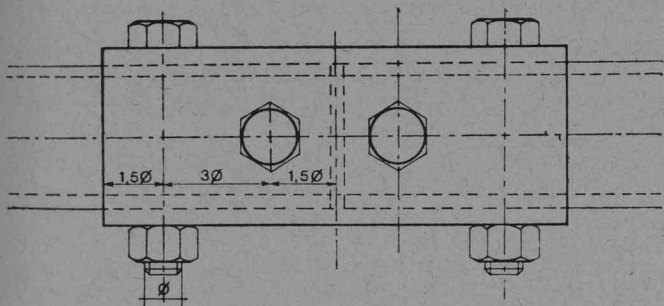

Dessin/drawing No 8

12 mm (tube < 40 mm diam. ext)
 $\phi = 14$ mm (tube ≥ 40 mm < 50 mm diam. ext)
 16 mm (tube ≥ 50 mm diam. ext)

Dessin/drawing No 9

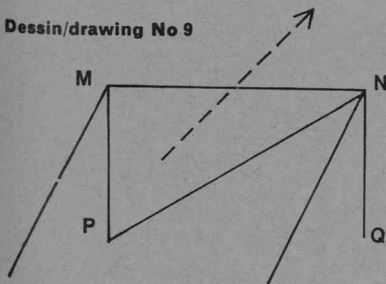

Groupe 6

Le montage d'un rentort diagonal est obligatoire. Les 2 variantes autorisées sont MQ et NP. (NP est indiqué sur le dessin no 9 comme un exemple.)

Group 6

Fitting of a diagonal strut is compulsory. The 2 authorised alternatives are MQ and NP. (NP is shown on drawing 9 as an example.)

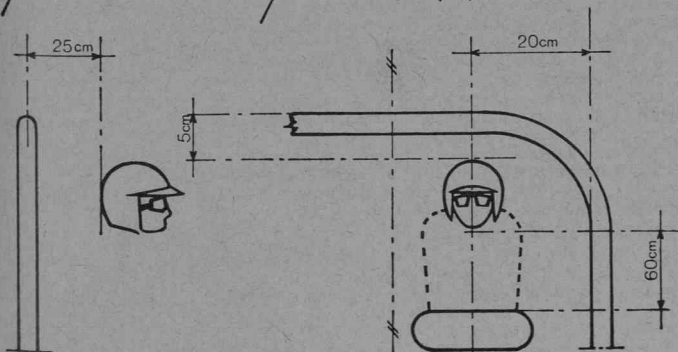

Dessin/drawing No 10

Art 253: Safety devices

This plate must have a total surface of at least 35 cm², a third of which at least constitutes the link with the vertical body component.

—a plate attached to the tube, having the same thickness as the metal of the tube to which it is fixed.

These two plates shall be joined together by at least three hexagonal headed bolts and nuts, at least 8 mm in diameter, or by at least three high tensile Allen head cap screws and nuts, at least 8 mm in diameter.

In no case may the roll-over bar be welded directly on to the body shell/chassis.

When the roll-bar rests on a box-member, the latter must be locally reinforced by a structure constituted of either welded bolts or welded tubing ends (see drawing 5).

In the case where the roll-bar is supported on a rear shelf which is not rigid enough, the roll-bar must be strengthened by adding struts, which must conform to roll-bar specifications (material, connections, fixation) between this rear shelf and car's monocoque.

D) Removable connections:

In case removable connections are used in the roll-bar construction, they must comply with a type approved by the FIA. Are approved up to now: a tapered connection and a twin lug connection with axls working under double shearing conditions and a muff-connection complying with drawings 6, 7 and 8.

The twin lug connection may however be used only for longitudinal brace-rods and not for the basic frame of the roll-bar(s).

The connection in accordance with drawing 7a may be used outside the main structure.

E) Application:

Specifications of the tubes utilised (Groups 1 to 5)

	Closed cars		Open cars	
	<1,200 kg	≥1,200 kg	<1,200 kg	≥1,200 kg
	Ext. Ø × thickness			
Cold drawn seamless carbon steel E ~ 30 daN	Ø 38 × 2.6	Ø 48.3 × 2.6	Ø 44.5 × 2.6	Ø 57 × 2.9
Alloy steel type 25 CD 4 SAE 4125 etc, E ~ 50 daN	Ø 33.7 × 2.3	Ø 42.4 × 2.6	Ø 38 × 2.6	Ø 48.3 × 2.6

These dimension figures represent in mm the minimum figures admissible. They correspond to standardised tubes (International Standards ISO R 64).

In the case of cars weighing more than 1,200 kg, the dimension figures prescribed for cars weighing less than 1,200 kg may be used for tubular elements other than the main hoop located behind the front seats.

NB: The FISA, conscious of the problem of habitability raised by the use of roll cages, suggests that each car manufacturer recommends a type of roll-bar complying with FIA Specifications for all cars in Groups 1 to 4.

This roll-bar will have to be entered on a recognition sheet amendment and submitted to the FISA for approval.

Important: The exact weight of the device shall be subject to a statement

from the competitor, to be appended to the entry form. This weight must be added to that indicated for the vehicle on the recognition form.

Application: Groups 1 and 3.

Cars of Groups 1 and 3:

Fitting compulsory for all speed events on circuits. Fitting optional for rallies, hill-climbs and slaloms. However, should the organisers of a rally or hill-climb deem that the driving conditions during their event are comparable to those of a speed event, they are entitled to prescribe the compulsory fitting of a safety roll-bar or cage, even for cars of Groups 1 and 3. This obligation must, in that case, be clearly mentioned in the Supplementary Regulations of the events.

Cars of Groups 2 and 4:

Fitting compulsory for all events. In rallies, the diagonal strut is not compulsory.

The safety cage, as shown in drawing No 2, provided for cars whose weight exceeds 1,200 kg, is compulsory for all cars whose cylinder-capacity exceeds 2 litres.

Cars of Group 5:

Fitting compulsory for all cars. The safety cage as shown in drawing No 2, provided for cars whose weight exceeds 1,200 kg, is compulsory.

Cars of Group 6:

All cars should be equipped with a safety roll-bar symmetrical about the longitudinal axis of the car.

In cars fitted with doors, the roll-bar will have a minimum height of 92 cm measured vertically from the lowest point of the entirely sprung structure of the car.

In cars without any door, the minimum height will be 120 cm. In any case, the top of the roll-bar must be at least at 5 cm above the driver's helmet when the driver is sitting in normal driving position.

Manufacturing of roll-bars, in conformity with the following table and drawings 9 and 10 (International Standards ISO R 64 except for $\varnothing 35 \times 2$), and to previous specifications concerning the removable connections and the general considerations.

The mounting of front stays to protect the driver is accepted on condition that they are removable, for open cars.

It is recalled that the safety roll-bar must be symmetrical about the lengthwise centre line of the car.

(Group 6)	Closed and Open Cars	
	<700 kg	≥ 700 kg
Cold drawn seamless carbon steel E ~ 30 daN	$\varnothing 42,4$ $\times 2,6$	$\varnothing 48,3$ $\times 2,6$
Alloy Steel type 25 CD4 SAE 4125 etc E ~ 50 daN	$\varnothing 35$ $\times 2$	$\varnothing 42,4$ $\times 2,6$

However, recognised and traditional manufacturers may also present a roll-

bar of free conception as regards the material used, the dimensions of the tubes and the implantation of the braces, providing that the construction is certified to withstand stress minima given hereafter.

w being the weight of the car in starting order (driver aboard, full tanks), the roll-bar must be able to withstand three simultaneously applied loads:

- 1.5 w lateral,
- 5.5 w fore and aft,
- 7.5 w vertical, these loads being carried over into the primary structure of the chassis.

A certificate signed by a qualified technician must be submitted to the Scrutineers of an event. It must be accompanied by a drawing or a photograph of the said roll-bar and state that this roll-bar can withstand the above mentioned loads.

Cars of Group 8:

Dimensions: The dimensions of the roll-bars must be as follows: the minimum height must be at least 36 inches (92 cm) measured along the line following the driver's spine, from the seat's metal shell to the top of the roll-bar. The top of the roll-bar must also be at least at 5 cm above the driver's helmet when the driver is sitting in normal driving position. The width must be at least 38 cm measured inside the roll-bar between the two vertical pillars of the sides. It must be measured at 60 cm above the seat's metal shell on the perpendicular to the line following the driver's spine.

Strength: In order to obtain a sufficient strength for the roll-bar, two possibilities are left to the manufacturers:

a) The roll-bar, of entirely free structural conception, must be capable to withstand the stress minima indicated on the scale hereabove (§ concerning cars of group 6).

b) The tubes and brace(s) must have a diameter of at least 1 $\frac{3}{8}$ inch (3.5 cm) and at least 0.090 inch (2 mm) wall thickness. The material should be molybdenum chromium SAE 4130 or SAE 4125 (or equivalent in DIN, NF, etc).

There must be at least one brace from the top of the bar rearwards at an angle not exceeding 60° with the horizontal. The diameter and material of the brace must be the same as those of the roll-bar itself.

In the case of two braces, the diameter of each of them may be reduced to 20/26 mm. Removable connections between the main hoop and the brace must comply with drawings No 6, 7, 7a, or with any other type approved by the FIA.

Forward fitted stays are allowed.

f) Safety fuel tanks approved by the FIA:

Entrants must use safety fuel tanks made by a manufacturer recognised by the FIA. In order to obtain the FIA's agreement, a manufacturer must have proved the constant quality of its product and its compliance with the specifications approved by the FIA.

Safety tank manufacturers recognised by the FIA must undertake to deliver to their customers exclusively tanks complying with the norms approved. To this end, on each tank delivered there shall be a printed code indicating the name of the manufacturer, the exact specifications according to which this tank has been manufactured and the date of the manufacturing.

1) Technical specifications:

The FIA reserves its right to approve any other set of technical specifications

Art 253: Safety devices

after study of the dossier submitted by the manufacturers concerned.

2) Specifications FIA/Spec/FT3:

The technical specifications for these tanks are available, on request, from the FISA Secretariat.

Ageing of tanks

The ageing of safety tanks entails a considerable reduction in the strength characteristics after approximately five years.

Therefore, all fuel cells must be replaced by new ones at the latest five years after the fabrication date indicated on the cell.

3) Specifications FIA/Spec/FTA:

The technical specifications for these tanks are available, on request, from the FISA Secretariat.

For reasons of vibrations, the fuel tank, if it is not made of rubber or of other elastic materials, should be suspended from the chassis by means of elastic supports (of a type similar to those used for the water radiators).

Note: In case this specification of fuel tanks would be used for cars of Group 6 the fitting of crushable structure would become optional.

4) List of recognised manufacturers

Federal Republic of Germany

Uniroyal, 5100 Aachen, Postfach 410

United States

Don Allen Inc, 401 Agee Road, Grants Has, Oregon 97526.

Aero Tec Labs, Hewson Avenue, Warcick, NJ 07463.

Fuel Safe Corporation, 15545 Computer Lane, Huntingdon Beach, California 92649

Goodyear Fuel Cell Labs, The Goodyear Tire and Rubber Company, Akron, Ohio 44316

France

Kléber-Colombes Division Tissus Enduits et Applications, 4 rue Lesage Maille, 76 230 Caudebec-les-Elbeuf

Ets J. RICHE-BP 14-14690 Pont-d'Ouilly.

Superflexit SA, 45, rue des Minimes, 92-Courbevoile

Great Britain

FTP Industries Ltd, The Airport, Portsmouth, Hants

Marston Excelsior Ltd, Wobaston Rd, Wolverhampton, Staffs

Premier Fuel Systems Ltd, Burnaston Old Airfield, Burnaston, Derby

Woodville Rubber Company Ltd, Hearthcote Road, Swadlincote, Burton-on-Trent, DE11 9DX.

Italy

Autodelta SpA (Alfa Romeo), Via Enrico Fermi 7, 20019 Settimo-Milanese

Pirelli, Viale Rodi 15, Milano

Japan

Kojima Press Ltd, 3-30 Shimolchibacho Toyota, Aichiken

Sakura Rubber Co Ltd, 48-14-1 Chome Sasazuka, Shibuya Ku, Tokyo

Sumitomo Electric Industries Ltd, 15-5 Chome Katahama, Migashi Ku, Osaka

5) Application of the different specifications

Cars of Groups 5-6-8: Compulsory fitting of a FT3 or FTA fuel tank in all events.

Cars of Groups 1-2-3-4: The cars of Groups 1 to 4 may be equipped with a

safety fuel tank, on condition that the necessary internal modifications do not affect the structural parts and the suspension mountings.

g) General circuit breaker: The general circuit breaker must cut all electrical circuits (battery, alternator or dynamo, lights, hooters, ignition, electrical controls, etc). It must be of a spark-proof model, and will be accessible from inside and outside the car. As for the outside, the triggering system of the circuit breaker will compulsorily be situated at the lower part of the windscreen mounting on the driver's side for closed cars, at the lower part of the main hoops of the roll-bar, *indifferently* on the right or the left, for open cars. It will be marked by a red spark in a white-edged blue triangle with a base of at least 12 cm.

Application: Compulsory fitting for all cars taking part in speed events on circuits or hill-climbs. The fitting is recommended for other events.

h) Oil catch tank: When cars are running in events which are entered on the FIA Sporting Calendar and when their lubrication system includes an open type sump breather, they must be equipped in such a way as to prevent oil from spilling on the track. In cars of a cylinder-capacity inferior or equal to 2,000 cc, the oil catching device shall have a minimum capacity of 2 litres and of 3 litres for cars with a cylinder-capacity exceeding 2,000 cc. The container shall either be made out of translucent plastic or include a transparent panel.

i) Rear view:

Cars of Groups 1-2-3-4-5: This shall be provided by an inside mirror commanding a rear window with at least a 10 cm vertical opening, maintained along a width of at least 50 cm (see drawing No 13). However, if the straight line connecting the upper and lower edges of the rear window opening makes an angle inferior to 20° with the horizontal, the rear view must be efficiently obtained by other means (two outside mirrors or any other system of equivalent efficiency). Furthermore, all these cars should be equipped with two outside mirrors for circuit events.

Cars of Groups 6 and 8: The mirrors must give the driver a rear visibility on either part of the car.

j) Braking safety system: Double circuit operated by the same pedal and complying with the following:

The pedal shall normally control all the wheels.

In case of a leakage at any point of the brake system pipes or of any kind of failure in the brake transmission system, the pedal shall still control at least two wheels.

Application: Compulsory fitting on all cars of Groups 2-4-5-6 and 8.

k) Towing-eye: All cars will be equipped with a rear and front towing-eye for all events. This towing-eye will only be used if the car can move freely and it must not be used to lift the car.

Application: Cars of Groups 1-2-3-4-5 and 6.

l) Safety fixing devices for windshields: Such devices may be used freely for all cars having a windscreen, without recognition. They are however not compulsory.

m) Windshield: A windshield made of laminated glass (or glass of the type 10/20) is compulsory.

Application: Groups 1-2-3-4 and 5.

n) Red warning light: A rearward facing red warning light of at least 15 watts should be mounted as high as possible on the centre-line of the car and be clearly visible from the rear. The warning light must be switched on by order of the clerk of the course.

Application: Cars of Group 8.

o) Tank fillers and air-vents: It is recalled that the tank fillers and their caps must not protrude beyond the coachwork.

The caps must be designed in such a way as to ensure an efficient locking action which reduces the risks of an accidental opening following a crash impact or incomplete locking after closing.

The fillers must be placed away from points which are vulnerable in case of a crash. The air vents must be located at least 25 cm to the rear of the cockpit.

Application: Groups 6-8.

p) Protection against fire: an efficient protective bulkhead must be fitted between the engine and the driver's seat for preventing the passage of flames in case of fire.

Application: Groups 1 to 8.

TITLE 4—GENERAL PRESCRIPTIONS

Art 254—Rule for changing from one group to another, and authorised amalgamation of groups: Cars originally belonging to a certain group, but which have been subject to duly declared modifications and/or additions that exceed the limits specified for the group concerned, may pass into a higher group, provided for in the supplementary regulations, with the prescriptions of which it complies under the following conditions:

Group 1 passes into Group 2 }
Group 3 passes into Group 4 } or eventually in Group 5
Groups 2 and 4 pass into Group 5

Art 255—Prescriptions common to all cars of Groups 1 to 6:

a) Chassis, ground-clearance: No part of the car should touch ground when one of its tyres is deflated.

b) Coachwork:

Convertible cars must comply in all respects with the specifications applying to closed cars if they run in an event under this form, or with the specifications concerning open cars if they run with the hood down or the hardtop removed.

Maximum outside dimensions: The overall width shall be 200 cm for all cars participating in events on circuits.

Minimum inside dimensions and minimum number of seats:

NB: If a modification authorised by Appendix J affects a dimension stated on the homologation form, it will not be possible to retain that dimension as an eligibility criterion for the car.

Definition of the term 'seat': The two surfaces constituting the seating cushion and the seat-back or backrest.

Seat-back or backrest: Surface measured upwards from the bottom of the spine of a person normally seated.

Seating cushion: Surface measured forwards from the bottom of the spine of the same person.

These two main parts of the seat must form an homogeneous construction and be entirely covered with upholstery (for example, in natural or synthetic textiles).

Cars with a minimum of 2 seats (see diagrams 11 and 13):

The two seats must be distributed equally on either side of the longitudinal centre-line of the car and at the same level, regardless of their normal play for adjusting them to the size of the driver. The location provided for placing or housing the two front seats must have a minimum width of 40 cm maintained all along the depth of the seat. The seats themselves must have identical dimensions.

The 'protected height' shall be at least 80 cm measured from the cushion of the seat compressed by the standard mass (see diagram 12) to the ceiling (any existing padding being compressed) in cars with closed coachwork and 80 cm from the surface of the seat compressed by the standard mass (see diagram 12) to the upper edge of the windscreen (measured vertically through the centre of the standard mass) in case of open cars.

The minimum interior width over the front seats (see measurement C) shall be of 100 cm in cars with a cylinder-capacity inferior or equal to 1,000 cc, 110 cm in cars with a cylinder-capacity from 1,000 cc to 2,000 cc and 120 cm in cars with a cylinder-capacity exceeding 2,000 cc. The minimum width of foot-space (for each person) must be at least 25 cm measured perpendicularly to the centre-line of the car, plumb with the pedals.

The distance between the lengthwise centre-lines of the seats should not be inferior to 50 cm. In case the two centre-lines should not be parallel, measurement should be done from the hollow of the seats.

The passenger's compartment and seat shall remain free throughout the competition and shall not be encroached upon by any element or equipment of the car except when Appendix J specifically provides otherwise. The passenger's compartment and seat of open cars shall not be covered.

c) Windshield-windshield wiper: A windshield made of laminated glass is compulsory. It shall be equipped with at least one automatic wiper sweeping a sufficient area to enable the driver to distinctly see the road from his seat.

The windshield shall comply with the following requirements:

- 1) Be placed symmetrically with regard to the centre-line of the car.
- 2) Have a minimum height of 25 cm, maintained between two points symmetrically placed with regard to the centre-line of the car and of which one is determined by the vertical line passing through the centre of the steering-wheel. There must furthermore be at least 60 cm between the two said points.
- 3) Have a minimum width of 100 cm; cord measured at half its vertical height.

Shall be considered as being the windshield, only the glass area through which one has an entirely free vision towards the front, without being limited by any outside opaque projection apart from the bulge of the mudguards which cover the front wheels.

d) Mudguards: Shall be of permanent nature and firmly fixed.

They shall project over the wheels and provide efficient covering of at least one third of their circumference, and at least the width of the tyre. In those cars

Largeur sur laquelle la "hauteur protégée" doit être maintenue
Width where the "protected height" must be maintained

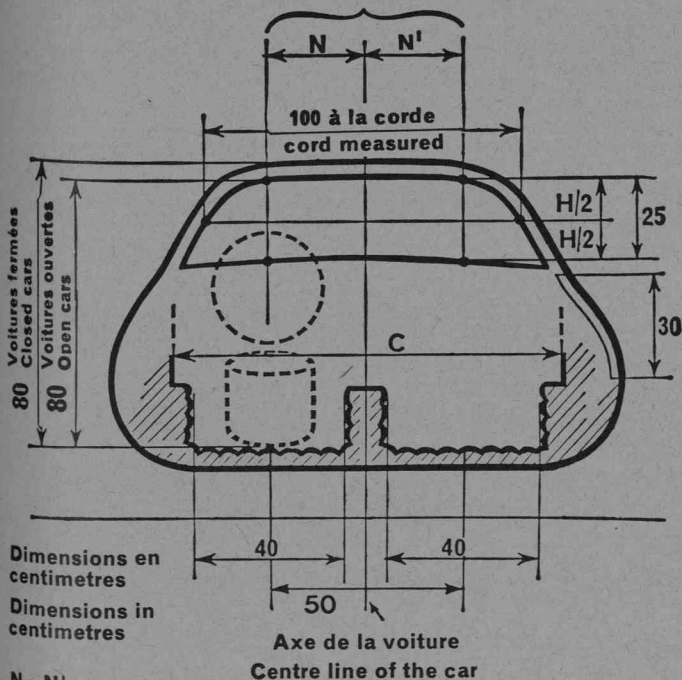

$$N = N'$$

$$N + N' = 60 \text{ cm min}$$

Dessin/drawing No 11

	0-1,000 cc	1,000 2,000 cc	2,000+ cc
C	100	110	120

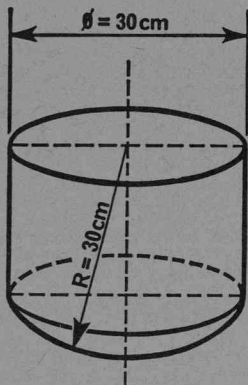

Weight/tare = 60 kgs \pm 200 grms.

Dessin/drawing No 12

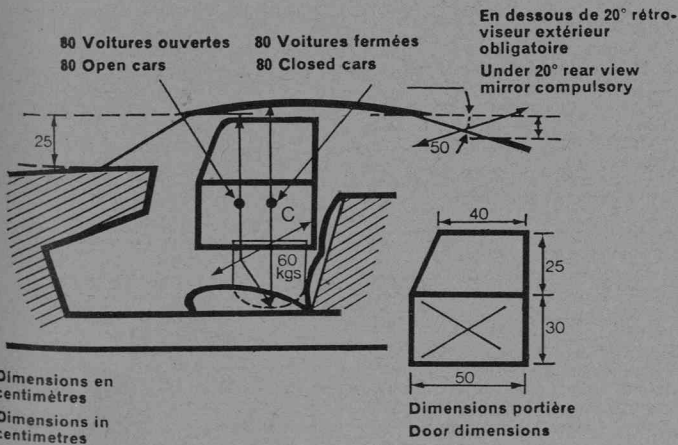

Dessin/drawing No 13

where mudguards are entirely or partly overhung by the body structure, the combination mudguards-body or the body alone shall nevertheless meet the above protection requirements.

Mudguards must be solid with the body, there being no gap between them, except as regards the openings mentioned under Art 269 b).

e) Doors: All vehicles shall be fitted with at least one rigid door on each side, with closing devices and hinges which may not be located on the rear-door post, nor on the door-sill. The outside door handle, in case of closed cars, must be clearly indicated. The dimensions of the lower door panel (the part which is normally opaque) must be such as to allow a rectangle of at least 50 cm wide and 30 cm high being inserted in it. The corners of this rectangle may be rounded to a maximum radius of 15 cm. Cars with sliding-doors will not be allowed unless they include a safety system enabling a quick and easy evacuation of the car's occupants in case of an accident.

Cars with closed or convertible coachwork shall have doors equipped with movable windows of the material provided by the manufacturer for the considered model, liable to be opened over at least one third of their surface in order to provide for ventilation, each window having a minimum width of 40 cm and a minimum height of 25 cm.

When opened, the doors must give free access to the seats. They must be made in such a way that they never restrict the lateral view of the driver.

By door should be understood the part of the coachwork opening to give access to the seats.

f) Luggage trunk: It is specified that the luggage capacity for FIA homologated cars is checked at the moment of homologation. Therefore, race scrutineers need not worry about minimum luggage space for all cars benefiting from an FIA homologation in Groups 1, 2, 3 and 4.

g) Fuel tanks: The total capacity of the fuel tanks (main and additional) must not exceed the following limits:

Cars up to	700 cc of engine cylinder capacity	:	60 l
Cars from	700 cc to 1,000 cc	" "	: 70 l
" "	1,000 cc to 1,300 cc	" "	: 80 l
" "	1,300 cc to 1,600 cc	" "	: 90 l
" "	1,600 cc to 2,000 cc	" "	:100 l
" "	2,000 cc to 2,500 cc	" "	:110 l
Cars over	2,500 cc	" "	:120 l

Will be considered as a fuel tank any container holding fuel which can flow out by any method either to the main-tank or directly to the engine.

The filling-port(s) (and vents) of each tank must always be outside the passenger-compartment and be entirely leak-proof.

Location of fuel tanks: The emplacement foreseen by the manufacturer for the fuel tank(s) and the feeding system towards the engine constitutes one of the principles of series-production, and this implies that no change can be made, unless an authorisation is explicitly stated in Appendix J.

However, a derogation to the above rule shall be made for cars in which the manufacturer has placed the fuel tank inside the passenger compartment, and close to the occupants.

In this specific case, and for the sake of safety, it will be possible, whatever the group of cars, to mount a leak-proof protective barrier between the tank

Art 255: Prescriptions Groups 1 to 6

and the passengers, or to change the place of the tank and, if necessary, its accessory parts (filling port, petrol pump, outlet tube).

h) Minimum weight: Is the real minimum weight of the empty car (without persons or luggage aboard) fully equipped.

All tanks containing liquids (lubrication, cooling, braking, and heating if necessary), except for the fuel tank, must be full, with the exception of the windscreen washer water container and that of the brake cooling system if the car is fitted with one.

By full is understood, to the level recommended by the manufacturer.

All safety devices normally supplied are included in these weights.

Cars from Groups 1 and 3 must carry a spare wheel which can be used in the place of any other of the car, as well as all the accessories normally fitted to the least expensive model of the series in question, except for the repair kit (jack, tool-kit) normally supplied.

Cars from Groups 2, 4, 5, 6: It is permitted to complete the weight of the car by one or several ballasts incorporated to the materials of the car, on condition that they are strong and unitary blocks, mounted by means of tools, and providing for the possibility to fix seals if the scrutineers deem it necessary.

A spare wheel may be used as ballast under the hereabove conditions.

The minimum weight of a car must be maintained throughout the duration of an event.

Scrutineers can therefore take a car on the finishing line, and weigh it after emptying the petrol tank and filling the other tanks containing liquids.

i) Silencer (muffler) and exhaust system: Even when the specific provisions for a group allow replacement of the original muffler, cars competing in an open road event shall always be equipped with an exhaust muffler complying with the road regulations of the country(ies) through which the event is run.

For events run exclusively on closed circuits, the supplementary regulations may authorise modification, replacement or removal of the exhaust muffler.

The outlet pipes of the muffler shall be directed either rearwards or sideways.

If the outlet pipes are pointing rearwards, their orifices shall be placed at a height neither superior to 45 cm nor below 10 cm; they shall not protrude by more than 15 cm beyond the overall length of the car. If the exhaust pipes are directed sideways, their orifices must be located aft of a vertical line passing through the wheelbase centre and may not project in any way beyond side of the coachwork. Adequate protection shall be provided in order to prevent heated pipes from causing burns.

j) Minimum lighting equipment: For all types of races, cars must be equipped with at least two 'Stop' lights plus two red tail lights, each fitted with a bulb of at least 15 w. In addition all cars in Groups 1 to 5 should be fitted with two headlamps as powerful as those normally found on Touring or Grand Touring cars. These headlamps should be in working order throughout the race, even if the race takes place exclusively in the daytime. Two direction indicators must be fitted at the rear.

For events run on open roads (rallies), cars must comply with the legal requirements of the country of the event; cars from other countries must comply in this respect with the Convention on international road traffic.

k) Supercharging: In case of supercharging the nominal cylinder-capacity will be multiplied by 1.4 and the car will pass into the class corresponding to the fictive volume thus obtained. The new cylinder-capacity of the car shall

always be considered as the real one. This shall particularly be the case for assigning the car to its cylinder-capacity class, and the car will be treated in all respects as if its cylinder-capacity thus increased was its real capacity. Especially in regard to its classification per cylinder-capacity class, its inside dimensions, its minimum number of seats, etc.

l) Limits of authorised modifications: Certain modifications to the original parts, certain additions and/or removal of accessories normally mounted by the manufacturer of the model concerned, are explicitly authorised by the present regulations. The limits of these modifications are set out for each of the groups 1 to 5. All those not explicitly mentioned as permissible for the group in which the car claims classification and which affect, even secondarily, the mechanical efficiency of the engine, the steering, the transmission, the road-holding and/or the braking, will render the car ineligible for the group requested.

If these modifications or additions have been the subject of a previous statement by the entrant, the car may be allowed to compete in the event in one of the other groups provided in the supplementary regulations and with the prescriptions of which it complies. Should there be however an obvious case of wilful misrepresentation, the entrant should not be authorised to start or should be stopped if he had already started, with request to the ACN concerned to pronounce his suspension for at least 12 months.

m) Fuel:

1) For all piston engines (reciprocating and rotary): By 'commercial fuel' to be used in motor car competitions, the Federation Internationale de l'Automobile intends to designate a 'motor' fuel produced by an oil company and currently distributed at road refuelling stations throughout one same country.

May therefore be used, in all races for which the use of commercial fuel is compulsory, all commercial fuels of the country in which the event takes place, with no other additive except that of a lubricant of current sale which cannot increase the octane number, or water.

May also be used, under the same conditions, any commercial fuel(s) which—in France, Germany, Great Britain and Italy—is (are) of the highest octane rating, according to the Research Method.

If the above-mentioned fuel could not be easily imported into the country where the event is taking place, it may be replaced by another one of similar quality and with the same octane number (RM)—with a tolerance of + 1—specially made by an oil company.

Whenever, in France, Great Britain, Germany and Italy, a new commercial fuel is made available which has a higher octane rating than those sold so far, the oil company producing this said fuel shall give notice to the FIA by a registered letter and this new commercial fuel (or its equivalent as specified hereabove) may be used for racing 30 days after the registered letter has been mailed.

The oil companies who supply fuel directly to the entrants of a race shall have to send to the promoters the characteristics and a sample of the fuel delivered in such quantity as is sufficient to carry out the necessary analyses, and also a declaration stating that the fuel complies with the present specifications.

2) For vehicles propelled by turbine engines: Kerosene used by commercial aviation companies for turbo-prop or jet engines or the fuel used by vehi-

cles with conventional type engines and complying with the hereabove definition of 'commercial fuel'.

n) **Combustive:** The engines must intake only ambient air.

Application: Groups 1 to 6.

o) **Application of general prescriptions:** The general prescriptions must be complied with if the particular specifications of groups of cars of Groups 1 to 6 do not mention them or do not provide for any stricter prescriptions.

p) **Anti-pollution legislation:** It is specified that the freedom left for the modifications of anti-pollution equipment is valid only as far as these modifications are not forbidden by the national laws of the country traversed.

SERIES-PRODUCTION TOURING CARS (Group 1)

Art 256—Definition:

Touring cars built on large series-production terms: The only working authorised is normal maintenance or the replacement of parts damaged through wear or accident and the modifications and additions explicitly authorised hereafter under Article 258. Except for what is explicitly authorised, any part damaged through wear or accident may only be replaced by an original part identical to the one damaged.

Art 257—Minimum production and number of seats: Series-production touring cars shall have been manufactured in 12 consecutive months in a quantity of at least 5,000 identical units and offer at least four seats, except if their engine cylinder-capacity is inferior or equal to 1,000 cc, in which case the manufacturer may deliver them as two-seaters.

Art 258—Mountings and modifications authorised:

a) **Lighting devices:** All lighting and signalling devices must comply with the legal requirements of the country of the event; cars from abroad must comply in this respect with the Convention on international road traffic.

Lighting devices which are part of the standard equipment must retain those foreseen by the manufacturer and must comply as far as is concerned their functioning with what the manufacturer has foreseen for the considered model. Thus, if changing from a road beam to a passing beam is produced by merely deflecting the beam inside one same reflector, this system may not be altered.

Freedom is granted with regard to the frontal glass, the reflector and the bulbs. The mounting of additional headlights is authorised provided that a total of six headlights is not exceeded (parking lights not included). Extra headlights may, if necessary, be fitted into the front part of the coachwork or into the radiator grille, but such openings as needed in this case must be completely filled by the additional headlights. The number of headlights and other outside lights must be even. Shall be considered as a headlight any lighting-device throwing a beam towards the front (dipped-beam, long-range lamp, anti-fog lamp). The fitting of reverse-lights is authorised, if necessary by embedding into the coachwork, but provided it will only switch on when engaging the reverse-gear, and provided the police regulations are respected.

The mounting of manoeuvrable search-lights on the roof or elsewhere is forbidden. Waivers may be granted to these specifications on condition that they be explicitly provided for in the supplementary regulations of the event.

It is permitted to modify the location of the signalling devices and the parking lights. The make of the lighting devices is free.

The supplementary regulations of an event may authorise the use of more than six headlights, within the conditions of the present article.

b) Fuel and oil tanks: Must be those normally homologated by the manufacturer for the model concerned, the capacities of which are specified on the homologation form (Art 252 g).

A safety fuel tank of a specification homologated by the FIA (FT3-FTA) (re Art 253 f) or that the manufacturer of the car considered will have had homologated by the FIA without any minimum production may be mounted on two conditions:

—Its capacity will be inferior or equal to the original fuel tank.

—The compartment of origin will be the same. It will also be allowed to install it in the luggage boot.

In no case will it be permitted to cut a hole in the floor of a car for the mounting of a safety fuel tank.

The use of a fuel filler with a vertical hose will be authorised for the series-production fuel tank and also the eventual safety fuel tank. However, no modification of the coachwork will be permitted, and the opening of the former fuel filler will be totally obstructed. Should the tank and its filler be located in the luggage compartment, an outlet must be provided for the fuel accidentally spilled in this compartment.

For circuit races where refuelling takes place, it is permitted to use the standard refuelling coupling recommended by the FISA, even if this means modification of the coachwork, so long as the part of the coupling fitted to the car does not protrude beyond the coachwork line. The use of a fuel tank with a larger capacity may be authorised by the ACN with the FIA's agreement, in the case of events organised under particular geographic conditions (on desert or tropical courses for instance).

The series fuel tank must be removed when another type of fuel tank is used.

c) Cooling circuit: If, for the same model, radiators of different capacities are normally provided, only those homologated for this model will be authorised.

The addition of a radiator screen is authorised.

The use of a radiator with a larger capacity may be authorised by the ACN with the FIA's agreement, in the case of events organised under particular geographic conditions.

Make and type of thermostat are free; however, it may also be removed. The radiator screen may be a rigid plate fixed behind the grille.

d) Induction: The carburettor(s) or fuel injector pump(s) normally mounted on the homologated model and described on the homologation form may not be changed or modified, except for any part which may control the quantity of fuel fed to the engine, but not those which control the quantity of air. It is permitted to remove the filtering element on condition that the original air filter box is retained.

In the case of a supercharged car, the supercharging system must conform strictly with the series.

e) Electrical equipment: The tension (voltage) of the electrical equipment may not be changed. In case of an electrical circuit under a 12 volt tension, this tension may be produced either by a 12 volt battery or by several batteries of an inferior voltage on condition these batteries remain in the original location, i.e. the coachwork compartment where it was originally mounted.

The make and capacity of battery, as well as the make and the output of the generator, are free.

Ignition coil, condenser, distributor and regulator are free, subject to the ignition system remaining the same as provided by the manufacturer for the model concerned.

However, it is specified that the fitting of an electronic ignition system is allowed on series-production cars provided no mechanical part other than those mentioned hereabove is modified or replaced.

Spark plugs: Make and type are free.

f) Gearbox—Final drive:

The fitting of an overdrive system in addition to the existing gearbox is authorised.

The use of an automatic gearbox is authorised but on condition this gearbox is foreseen by the manufacturer and mentioned on the homologation form.

In this case, however, the differential ratio provided for the automatic box on the homologation form should be used, with the exception of the ratios provided for the manual box.

The gear change lever must be in the location or locations designed by the manufacturer and mentioned on the homologation form. Its shape and length are free.

Each set of gearbox ratios entered on the homologation form should be considered as a unit.

g) Shock absorbers: The make and type are free. However, no addition is allowed and neither their original purpose nor their number, nor their system of operation may be modified. By system of operation is meant: hydraulic, friction, telescopic or lever type. The original supports may not be changed in any way.

If, in order to change the damping element of a McPherson suspension, it is necessary to replace the entire McPherson strut, the replacement part must be mechanically identical to the original one, except for the damping element.

In this case, suspension geometry must remain unchanged, and the characteristic angles of the suspension and the wheel must continue to correspond to the original ones.

h) Wheels and tyres: Wheels are defined by their diameter, the width of their rim and the track they determine.

The four wheels must always belong to the same homologation set for the considered model.

Tyres are free (make and type) on condition they are tyres provided by their manufacturer to be fitted on the wheels without any intermediary device.

However, they will have to conform with the regulations of the country where the event takes place for events being run on roads open to traffic, and they will

be left at the choice of the organisers for other events.

All special or additional non-skid devices for snow or ice may also be fitted.

However, the FISA reserves its right to prohibit the use of studded tyres for events run on open roads.

All cars shall be equipped with at least one spare-wheel occupying the position provided for by the manufacturer which may not encroach upon the space provided for luggage.

The spare-wheel must be equipped with a type of the same nominal tread circumference as those fitted on at least two wheels of the car. It must be serviceable under all circumstances.

j) Brakes: Must be those provided by the manufacturer. The replacement of worn linings is authorised and their system of attachment is free, provided the dimensions of inner friction surfaces remain unchanged (Art 252 m). Servo-assistance and pressure limiting valves are only permitted when duly homologated concerning a number of identical cars equal to that required for basic homologation.

If a servo-assistance is normally provided for on a car, the servo device may be disconnected.

It is permissible to fit a dual braking system on condition that it be of the same make as that of the hydraulic master cylinder or provided by the manufacturer of the vehicle and that it has been homologated without minimum production.

The material and method of fixation of the brake linings are free.

j) Clutch: The material and method of fixation of the clutch linings are free.

k) Supplementary accessories not included in the homologation: Are authorised without restriction provided they have no influence whatsoever on the behaviour of the car, such as those concerning the aesthetics or the inside comfort (lighting, heating radio, etc), provided they do not affect, even indirectly, the mechanical performance of the engine, the steering, the transmission, the road holding and the braking.

All controls and their functions must remain those provided by the manufacturer, but it is permissible to arrange them in such a way as to make them accessible and easier to use, ie, lengthening of the handbrake-lever, fitting of additional pads to the brake-pedal, etc. The position of the steering-wheel may be indifferently on the left or on the right, provided this only results in a simple transposition of the steering-system linkages as provided and supplied by the manufacturer and without any other mechanical alteration (tubing, etc).

The following is authorised:

1) The windshield may be replaced by a windshield of same material but with a heater-defroster device incorporated.

2) The original heater may be replaced by another one provided by the manufacturer and mentioned in his catalogue as available on request.

3) All freedom is left regarding the mounting or the replacement of all gauges, meters, etc. However, this mounting should represent no danger.

4) The horn may be changed or an extra one may be added, at the disposal of the passenger if wished.

5) The mechanism of the handbrake lever may be adapted for obtaining an instantaneous unbolting (fly-off handbrake).

6) All electrical switches may be freely changed, inasmuch as is concerned their purpose, their location and, in case of the adding of extra accessories, their number.

7) Extra relays and fuses may be added to the electrics; battery wires may be lengthened. The original accelerator cable may be replaced by another one, whether supplied or not by the manufacturer.

8) Seat brackets may be altered and any kind of seat-covers may be added, even those which constitute a bucket-seat.

9) Jacking points may be strengthened; their location may be changed or extra ones be added.

10) Head-light covers may be fitted provided they do not influence the streamlining of the car.

11) Complete freedom is left with regard to the location and appearance of registration number plates, in consideration of the great differences between legal requirements from one country to another.

12) The luggage boot may be adapted for better accommodation of the equipment carried (straps for fixing a tool-box, protection of a supplementary fuel-tank, of an additional spare-wheel, etc). The attachment system of the original spare-wheel may be altered provided its original location is not changed.

13) Extra compartments may be added to the glove-box and extra lateral pockets to the doors.

14) Plates of insulating material may be added in all places where they may be necessary to protect those carried aboard the car from a risk of fire.

15) An oil-catch tank or a water-catch tank may be fitted (Art 253 h).

16) The radiator filler cap may be locked by any means.

17) Safety fasteners may be provided for the windshield.

18) The steering-wheel is free.

l) Coachwork: None of the normal elements of the coachwork (dashboard, all inside quiltings whatever their location) may be removed or replaced, and none of the accessories normally mounted by the manufacturer on the lowest priced model may be removed.

However, the modifications deriving from the fitting of the supplementary accessories authorised in the preceding paragraph, such as those necessitated by the addition of a windscreen washer (drilling of a hole into the bonnet) will be allowed.

Transparent parts must, in case of damage, be replaced by others made of a material identical to the original one listed on the homologation form. They shall be completely interchangeable with those originally fitted. They must be mounted on the original supports and their original opening system (if any) must be maintained.

Nuts and bolts may be freely exchanged and locked by pins or wires.

Wheel-spats which are part of the coachwork must be removed.

m) Bumpers, embellishers, streamlining: Bumper overrides may be removed.

Wheel embellishers must be removed. The addition of any protective device underneath the car is forbidden unless such a device is mentioned on the homologation form of the model in question or is authorised or made compul-

sory by the supplementary regulations of the event.

n) Reboring dimensions: A maximum reboring dimension of 0.6 mm will be authorised on condition that the piston be the original one and that the cylinder-capacity class remains the same (Art 252 h).

Tolerance scale:

1) Tolerances for all machining, excepting bore and stroke: 0.2%. (Articles 148, 150, 74, 75, 161, 171, 185, 186, 192, 211, 212 and also the orifices appearing on page 15 of the homologation form).

2) Article 144: tolerance $\pm 0.5\%$.

3) Unfinished castings: $+4\% -2\%$.

4) Valve-lift: $+1\%$ (Articles 162, 172, 205).

5) Weight (Articles 151 to 156): $+7\% -3\%$.

6) Width of the car at front and rear axles: $+1\% -0.3\%$.

7) Wheelbase (Article 3): $\pm 1\%$.

8) Track (Art 110 and 111): ± 25 mm.

Former homologation form:

1) Art 156-158-159-181-196-215-216-225-262-263 orifices p 8.

2) Art 146.

4) Art 182-197-255.

5) Art 160 to 164.

7) Art 1.

TOURING CARS (Group 2)

Art 259—Definition: Cars of series-production which may be submitted to certain modifications aimed at making them better suited to competition. The list of the modifications and additions authorised is given hereafter under Art 261.

Moreover, in this group, may be classed cars of Group 1 which have been the subject of modifications and/or additions exceeding the limits of Group 1. These cars will then enjoy the same freedom as provided for Group 2.

Art 260—Minimum production and number of seats: Touring cars shall have been manufactured in a quantity of at least 1,000 units in 12 consecutive months and be equipped with at least four seats; however, if their cylinder-capacity is equal or inferior to 1,000 cc, they may be delivered as 'two seaters'.

Art 261—Modifications and additions authorised: All those already authorised in Group 1, plus those contained in this article.

a) Minimum weight: The minimum weights of the cars must be the following (see Art 255h):

Up to	500 cc:	495 kg	Up to	3,500 cc:	1,050 kg
" "	600 cc:	535 kg	" "	4,000 cc:	1,115 kg
" "	700 cc:	570 kg	" "	4,500 cc:	1,175 kg
" "	850 cc:	615 kg	" "	5,000 cc:	1,225 kg
" "	1,000 cc:	655 kg	" "	5,500 cc:	1,280 kg
" "	1,150 cc:	690 kg	" "	6,000 cc:	1,330 kg
" "	1,300 cc:	720 kg	" "	6,500 cc:	1,365 kg
" "	1,600 cc:	775 kg	" "	7,000 cc:	1,405 kg
" "	2,000 cc:	845 kg	" "	7,500 cc:	1,425 kg
" "	2,500 cc:	920 kg	" "	8,000 cc:	1,445 kg
" "	3,000 cc:	990 kg	Over	8,000 cc:	1,530 kg

b) Modifications of the original mechanical parts: The original mechanical parts having undergone all the normal machining operations foreseen by the manufacturer for series-production, except those for which the present article provides a freedom of replacement, may be subject of all perfecting operations by means of finishing or scraping, but not replacement. In other words, provided the origin of the series-production part may always be ascertained undoubtedly, this part may be rectified, balanced, adjusted, reduced or modified in its shape through machining. This permission however does not apply to brake callipers. Any adjunction of material in an homogenous way (welding, gluing, electrolysis) is forbidden for the following mechanical elements: engine, gear-box, transmission, suspension parts.

c) Engine—cylinder-heads and valves: Besides the modifications which can be carried out on the cylinder-head as specified under paragraph b), complete freedom is left as regards valves, valve-guides and valve-seats. The number of valves per cylinder cannot be modified. It is allowed to add washers to the valve-spring assembly.

Valve-springs are submitted to no restriction as regards their number and type, provided the modifications remain within the limits provided for in b).

d) Engine—induction system and elements: Free. However, supercharging will be forbidden if not homologated.

In case a supercharging system would be homologated in series, complete freedom is granted in so far as its preparation is concerned.

A turbocharger may not be replaced by another type of compressor and vice versa.

(Turbocompressors remain turbocompressors, mechanical compressors remain mechanical compressors, etc.)

e) Engine—reboring: No overlapping of cylinder-capacity class is allowed (Art 252 i). A 0.6 mm maximum reboring is permitted in relation to the original series bore. It is permitted to sleeve (or re-sleeve) the engine within the authorised dimensions.

By sleeve, it will be understood the metal cylinder inside which the piston moves. This part will be a separate component which will be fitted in the block in different ways: pressed, welded, etc.

The material will be free. In case the engine would be directly bored and no intermediate part used, it will be possible to add a sleeve, the material of which will be free. An addition of material will be permitted inside the cylinder, by way of derogation to Art 261 b).

f) Engine—exhaust system and elements: Free. The piping will however be conceived in such a way as to end on one of the sides or at the rear of the car.

However, for all types of events, organisers may provide for a particular restriction, which will be mentioned in the regulations of the event. Besides, for events run on open roads, the efficiency of the mufflers must conform to the legal prescriptions of the country where the event is run.

g) Engine—bearings: Plain, or roller bearings may be replaced by others of the same type.

h) Engine—gaskets: Gaskets may be replaced by others or suppressed.

i) Engine—lubrication system: The oil sump is free. The oil pump may be modified provided its original body is retained.

The number of oil pumps originally fitted cannot be changed.

A dry sump lubrication system is forbidden, unless homologated (see Art. 261-66).

Oil filters and oil coolers are free (type, number and capacity). The fitting of an oil cooler exterior to the coachwork is only permitted below the horizontal plane passing through the centre of the wheel-hubs. In no case, such a fitting of an oil cooler may result in the addition of an aerodynamic enveloping structure. Moreover, the oil cooler must not constitute a protuberance outside the general car perimeter, seen from above, such as presented on the starting line.

j) Engine—camshafts and valve gear: Free. Yet, the location, number and driving system of the camshaft(s) cannot be changed (chain, belt, gears, con-rods, etc).

The freedom concerning the camshaft(s) does not apply to its (their) emplacement(s) nor housing(s).

k) Engine—piston, piston axle and piston rings: Free.

l) Engine—other elements: Mountings are free. The cooling fan and water-pump may be modified, replaced or suppressed.

There is no restriction for the fuel pumps as regards number, type, location and output. Nevertheless, it must never be located in the passengers' compartment.

The inclination and the position of the engine inside the engine compartment are free, provided however the implied modifications do not go beyond what is allowed in Art 261 b, l, m and n.

m) Transmission: The homologated gear-box ratios, including those eventually homologated for Group 1, may be mixed, on condition that the gears are not combined into a one piece gear unit. The number of ratios of the gear-box(es) of origin must be retained. The synchronisation system of origin must be retained.

Selection forks may be reinforced by addition of material, by way of exception to Art 261 b).

Mountings are free. The location and type of the gear lever are free. The gearbox casing should remain that of origin, within the limits of the modifications permitted in paragraph b). The original principle of lubrication of the box should be retained; however a cooling device for the gear-box oil is authorised (circulation pump and radiator).

For cars fitted with automatic gear-box, a complete freedom is left for the ratios on condition that their number is unchanged. The torque converter is free.

Differential: Mountings are free. The differential ratio must be homologated. A limited-slip or self-blocking differential may be fitted, provided it can be located in the casing without entailing a modification beyond that allowed under paragraph b). All the transmission shafts and joints between the engine and the wheels are free.

The original principle of lubrication must be retained; however a cooling device for the oil is authorised (circulation pump and radiator). A complete freedom is left as regards pulleys and belts for belt transmissions.

Clutch: The clutch will be free on condition that it has the same number of discs as the series-production clutch and that the original bell-housing and flywheel are retained.

n) Suspension: It is permitted to modify the original parts of the suspension

according to the specifications of Art 261 b). The addition or suppression of an anti-sway bar is permitted. This anti-sway bar must play no other part in the suspension.

The material and dimensions of the main spring are free, on condition that it remains unique in the performance of its function.

The addition of auxiliary springs is permitted on condition that the main spring of origin be retained unchanged.

The shock absorbers anchoring points may be reinforced.

The fitting of joints of a different type and/or material is authorised. Pivoting points must remain in their original location.

o) Steering: The steering ratio is free, provided that the original steering box is kept. A servo steering system may be disconnected.

p) Wheels and tyres: Free, provided their fitting can be carried out in full conformity with Art 255 d) and in so far as the complete wheel (Art 252 l) width in relation to the cylinder-capacity of the car does not exceed the following dimensions:

Up to 1,300 cc:	9"
" " 1,600 cc:	10.5"
" " 2,000 cc:	11.5"
" " 3,000 cc:	13"
" " 5,000 cc:	14"
" " 6,000 cc:	15"
Over 6,000 cc:	16"

Moreover, the four wheels of a car must always have the same diameter (Art 252 l). The spare-wheel is not compulsory. However, in case one should be installed, it must be firmly attached, not installed within the space reserved for the driver and the front passenger, and not entail modifications in the outside aspect of the coachwork.

It is specified that the track is free.

q) Electrical equipment—lighting equipment: Free. Yet for events on open roads, the vehicle must be in compliance with the police regulations of the country where the event is run or with the international convention on road traffic (Art 255 k).

The replacement of a rectangular headlight by two circular ones fitted on a support corresponding to the dimensions of the aperture and sealing it completely is allowed.

The liberty given for the lighting devices concerns their replacement or modification, but does not allow their suppression.

Their number should be even. The minimum lighting equipment should remain in normal functioning conditions during the whole event. Two stop lights are compulsory.

The location(s) of the battery(ies) is(are) free. It(they) must not be placed in the passenger compartment. In the case of one or several batteries being placed inside the passenger compartment of a car in normal production, it(they) may remain there provided that it is(they are) adequately protected.

Electrical system—engine accessories: It is allowed to replace a dynamo by an alternator and vice-versa. Its mounting brackets and crankshaft pulley are free. The generator may be removed or put out of use. The ignition system is free on condition the modifications involved are authorised in Art 258 e). The fitting of a double ignition system is not allowed, except if homologated with a

minimum production equal to that of the basic homologation.

The make and type of the starter motor are free.

r) Fuel tanks and water radiators: The capacity of fuel tanks is limited by Art 255 g).

The fuel tank may be replaced either by a fuel tank homologated in accordance with Art 261 bb (in the site provided for it by the manufacturer when this fuel tank was homologated), or by an FIA homologated safety tank (minimum specifications FT3). If the original is retained, its site may only be changed in accordance with Article 255 g).

Should the tank and its filler be located in the luggage compartment, an outlet must be provided for the fuel accidentally spilled in this compartment.

The location and dimensions of the filler orifice as well as those of the filling cap may be changed, provided the new fitting does not protrude beyond the coachwork line and provides against fuel leakage into the inside compartments of the car.

There is complete freedom as regards the water radiator and its capacity. Its location may be changed provided no modification is entailed either to the outside or to the inside (habitable) of the coachwork.

s) Braking equipment: The mounting of a double master-cylinder or of any device which produces simultaneous action on the four wheels and a separate action on two wheels at least is compulsory.

The discs may be replaced by others provided the area of the friction surface is not modified; the same does apply to the drums.

Changing discs to drums and vice-versa is forbidden.

Linings are free. The backing plates may be modified and fitted with air openings. Protection shields may be modified or suppressed. Cooling air-ducts may be added provided they do not entail a modification of the coachwork.

The addition or the suppression of brake servos is allowed.

It is not permitted to modify the disc callipers which can only be replaced by callipers homologated by the manufacturer without minimum production (re Art 261 bb).

A brake-cooling system using an additional liquid may be homologated with no production minimum. The liquid used must obligatorily be water.

t) Cables and pipes: It is allowed to entirely modify the arrangement, location and materials of all cables and pipes providing for the passage of fluid elements (air, water, fuel, electric currents, etc, including the suspension system).

The fuel and high temperature liquid pipes and air ducts should not pass through the habitacle, except if this mounting is realised in series. In all cases, these pipes should be efficiently protected.

u) Springs: Any spring, including its abutment(s), may be modified or may be replaced by another one of similar type (ie, leaf spring, coil-spring, etc) except in the case of the suspension where Art 261 n) applies. Its original location must be retained.

v) Coachwork—Chassis: Any lightening or modification which is not expressly permitted is forbidden. Any kind of reinforcement is permitted. The front seats and their mounting brackets may be replaced.

It is permitted to remove the rear seating arrangements, as well as the passenger seat. However, when the rear seating arrangements are removed, cars shall be fitted with a rigid metallic partition flame and liquid proof which will

Art 261: Group 2

separate the passengers' compartment from the engine compartment and fuel tank.

The moving rearwards of the front seat beyond the vertical plane defined by the front edge of the original rear seat, is not allowed.

It will be forbidden to install anything except the fire extinguisher, the roll-bar, and, according to the case, the spare wheel inside the passengers' compartment.

The removal of exterior decorative side strips is allowed.

It is allowed to fit aerodynamic devices on the front part of the car below the horizontal plane passing through the centre of the wheel-hubs. Nevertheless, these aerodynamic devices shall not protrude beyond the overall perimeter of the car, seen from above.

All homologated windows and winding mechanisms should be retained. The original rear window should also be retained. Non-visible insulating material may be removed. Trimmings of the passengers' compartment, of the door panels, etc, which are normally provided for cars of the series-production may be lightened but not removed. The original aspect of the inside must be kept. It is also permitted to remove the glove-box lid and the floor carpets.

It is permitted to widen the wing by beating, within the limits foreseen by Art 261 cc) (wing extensions).

It is specified that when the fitting of a safety element required by the regulations (double braking circuit for example) entails the modification of structural elements, this modification must be duly homologated (without production minima).

Additional fasteners: At least two fasteners, able to be operated from the outside, are compulsory on each bonnet and boot lid.

Should the modification made be considered a modification of the coachwork, it should be homologated by the manufacturer, with no production minimum.

In addition, for all competitions on closed roads, competitors must render inoperative the original fasteners, and the safety catch, if there is one. On open roads, this measure is left to the discretion of competitors.

Bumpers: Changing bumpers is no longer authorised in rallies.

Bumpers which are not integrated may be removed for events run only on closed tracks. However, no brackets may protrude beyond the coachwork.

The material of which coachwork-integrated bumpers are made may be changed, provided that the new mounted bumpers have the same shape and dimensions as the original ones and that they are no heavier.

w) Heating system: It is permitted to remove the heating devices and their accessories on condition that the demisting of the windshield and the rear window remains assured, if provided in series.

bb) Optional equipment which may be homologated without a minimum production:

(This paragraph must be applied in conformity with Articles 259, 260, and 261.)

—Reinforced suspension elements and rear/front axles, provided they are absolutely interchangeable with the original part and that the pivoting points to the chassis remain in their original location and that the kinematics of the suspension is not modified.

—Different dashboard.

—Brakes—brake callipers (the brakes may possibly be of a different type)

and brake cooling devices.

- Fuel tanks.
- Steering rods.
- Servo steering (Art 261 o).
- Dry sump engine lubrication.

cc) Free equipment which need not be homologated:

- Underneath protections.
- Wing extensions: Simple deflectors of at least 120° and of 5 cm maximum width and 10 cm maximum height and of free material.

These wing extensions shall cover the rearward wheel opening over at least 60° in relation to the vertical taken through the hub (see drawing 14).

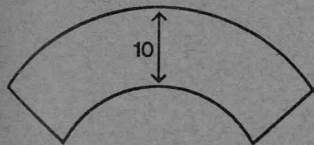

Front view

Drawing No 14



Side view

For measuring the maximum width, the measurement is to be done at the vertical going through the centre of the wheel hubs. It is permitted to cut the existing wing under the wing extension.

Fitted pneumatic jacks installed in the car are allowed subject to their installations respecting Article 261 in full, and that in particular neither the bodywork nor the cockpit were modified in any way.

SERIES-PRODUCTION GRAND TOURING CARS (Group 3)

Art 262—Definition: Cars with at least two seats, manufactured on a limited series-production scale for the drivers who seek the best possible performances and/or the greatest comfort.

Art 263—Minimum production and number of seats: Grand Touring Cars must have been manufactured in a quantity of at least 1,000 units identical in all respects (unless the authorisations, listed hereafter under Art 264, specify otherwise) over a period not exceeding 12 consecutive months and be equipped with at least two seats.

Art 264—Modifications and/or additions authorised: Exactly the same as those authorised for Group 1 (see Art 258).

GRAND TOURING CARS (Group 4)

Art 265—Definition: At least two-seater cars manufactured on a small series-production scale, and which may be subject to modifications in order to be more particularly adapted to sporting competition. This group also includes cars derived from those homologated in Group 3 (Series-production GT cars) and modified beyond the limits allowed for Group 3.

Art 266—Minimum production and number of seats: The Grand Touring cars must have been manufactured in a quantity of at least 400 units over a

Art 267: Group 4/Art 268-69: Group 5

period not exceeding 24 consecutive months, and be equipped with at least two seats.

Art 267—Modifications authorised: Exactly the same as those authorised for Group 2 (Touring Cars) (see Art 261), with the exception of the following weights (Art 255 h):

Up to	500 cc:	495 kg	Up to	3,500 cc:	1,005 kg
" "	600 cc:	535 kg	" "	4,000 cc:	1,075 kg
" "	700 cc:	570 kg	" "	4,500 cc:	1,120 kg
" "	850 cc:	615 kg	" "	5,000 cc:	1,170 kg
" "	1,000 cc:	655 kg	" "	5,500 cc:	1,225 kg
" "	1,150 cc:	670 kg	" "	6,000 cc:	1,270 kg
" "	1,300 cc:	700 kg	" "	6,500 cc:	1,310 kg
" "	1,600 cc:	740 kg	" "	7,000 cc:	1,340 kg
" "	2,000 cc:	810 kg	" "	7,500 cc:	1,365 kg
" "	2,500 cc:	880 kg	" "	8,000 cc:	1,380 kg
" "	3,000 cc:	945 kg	Over	8,000 cc:	1,465 kg

SPECIAL PRODUCTION CARS (Group 5)

Art 268—Definition: Special production cars for which no minimum production number is required, but which are derived from those cars benefiting from a valid homologation in Groups 1 to 4.

Art 269—Modifications allowed: All modifications authorised for Groups 1 to 4 (Art 258 and 261) are permitted, as well as those specified in the present chapter.

a) Minimum weights: Cars will weigh at least the following weights (Art 255h):

Cylinder-capacity inferior or equal to	500 cc:	450 kg
" " " " " "	600 cc:	495 kg
" " " " " "	700 cc:	525 kg
" " " " " "	850 cc:	555 kg
" " " " " "	1,000 cc:	585 kg
" " " " " "	1,150 cc:	610 kg
" " " " " "	1,300 cc:	635 kg
" " " " " "	1,600 cc:	675 kg
" " " " " "	2,000 cc:	735 kg
" " " " " "	2,500 cc:	800 kg
" " " " " "	3,000 cc:	860 kg
" " " " " "	3,500 cc:	915 kg
" " " " " "	4,000 cc:	970 kg
" " " " " "	4,500 cc:	1,025 kg
" " " " " "	5,000 cc:	1,065 kg
" " " " " "	5,500 cc:	1,115 kg
" " " " " "	6,000 cc:	1,155 kg
" " " " " "	6,500 cc:	1,190 kg
" " " " " "	7,000 cc:	1,220 kg
" " " " " "	7,500 cc:	1,240 kg
" " " " " "	8,000 cc:	1,255 kg
" " " " " "	over 8,000 cc:	1,330 kg

b) Coachwork—chassis:

b1) Coachwork: The outside shape of the original coachwork must be retained, except as concerns the wings and the aerodynamic devices allowed. Trim-strips, mouldings, etc. may be removed. Windscreen wipers are free, but there must be at least one in working order. The highest figure in Art 6 of the homologation form (Art 4 of the old form) shall be taken into consideration for limiting the overall length of the coachwork. The car's overall maximum width is limited to two metres.

b2) Bodyshell—chassis: No modification may be made in the series-production bodyshell and/or chassis, except as concerns lightening the original basic structure by removing material and/or adding reinforcements.

b3) Doors, bonnets and bootlids: Their material is free, provided that their original outside shape is retained.

Door hinges and outside door handles are free: the original lock must be retained.

The locking devices on the bonnet and bootlid, as well as the hinges, are free.

There must be four locking devices, and opening from the outside must be possible. The original closing system must be removed. Openings may be made in the bonnet for ventilation, provided that they do not make mechanical components visible. In all circumstances, the bonnets and bootlids must be interchangeable with the original homologated ones.

b4) Glass surfaces: Except for the windscreen, the material is free, provided that windows are transparent. However, the window in the driver's door, and the one in the passenger's door, if the event's supplementary regulations permit one, must be made of the original homologated material.

The original opening of this (these) window(s) must be retained and must be equal to one-third of the minimum surface required in Art 255 e). The opening of the rear windows is free. The way they are attached is free.

Sliding windows will be authorised.

b5) Cockpit ventilation openings: Openings may be made in the coachwork for ventilating the cockpit, provided that they are placed:

—at the rear roof edge above the rear window and/or in the area between the rear side window and the rear window;

—that they do not protrude beyond the original line of the coachwork.

b6) Wings: The material and shape of the wings are free. However, the shape of the wheel arches must be retained, but this does not imply that their original dimensions must be retained. The wings shall project out over the wheels and provide efficient coverage over at least one third of their circumference and at least the whole width of the tyre.

Openings for cooling may be made in the wings. However, should they be made behind the rear wheels, louvres must make it impossible to see the tyre from the rear along a horizontal plane.

The inside of the wings is free. It is therefore permitted to install mechanical components there.

b7) Interior: Interior trim, door panels, etc are free.

The dashboard must have no protruding angles. The seat must be located entirely on one side or the other of the longitudinal vertical plane passing through the middle of the car.

The bulkheads separating the cockpit from the engine compartment and the

boot must retain their original place, shape, and material. Installing components up against or passing through one of these bulkheads is however permitted, provided that this does not protrude into the cockpit more than 20 cm (as measured perpendicularly to the bulkhead). This possibility does not apply to the engine block, sump, crankshaft, or cylinder head.

In addition, the floor may be modified, provided that it is not made higher than the door sills. In this case, the original floor may be removed.

It is also permitted to make the modifications necessary for installing a new transmission.

The tubes, pipes, and electrical lines running through the cockpit must comply either with the prescriptions of Art 253 b), or with aviation norms.

Except for components installed up against or through bulkheads, only the following accessories may be installed in the cockpit: spare wheel, extinguisher, medical air, communication equipment, ballast.

c) Mechanical components: No mechanical component may protrude beyond the car's original coachwork, except inside the wings.

c1) Engine: The original cylinder block homologated on the basic car should be retained. The cylinder-capacity will be free, and may be obtained by changing the bore and/or the original stroke. Sleeving/resleeving are free. The engine should be located within the original engine compartment, and the original orientation of the crankshaft seen from above should be retained.

It is not permitted to use several engine blocks.

c2) Transmission: The driving wheels of the homologated basic model must remain the driving wheels. This implies that a four-wheel-drive transmission can only be used on a car so designed at the origin. The gear-box must remain in its original compartment for instance, in front of or behind the engine, at the driving axle, etc. Adding any device for stepping up the gearing is authorised.

c3) Other mechanical components: Free.

d) Suspension: The type of suspension homologated must be retained. However, it is permitted to modify or add fixation points, to modify or replace the connection units of the suspension system. The type and the number of springs and dampers are free.

By type of suspension is meant: McPherson, rigid rear axle, De Dion rear axle, wishbones, trailed wheel, etc.

The wheelbase of origin must be retained (tolerance $\pm 1\%$ according to Art 258).

e) Steering: Free.

f) Wheels: Free. However, the following maximum complete wheel (see Art 252 l) widths, in relation with the cylinder-capacity, will be authorised:

Up to 1,000 cc: 11"

" " 1,300 cc: 12"

" " 1,600 cc: 13"

" " 2,000 cc: 14"

" " 3,000 cc: 15"

over 3,000 cc: 16"

g) Brakes: Free (Art 253 j).

h) Tanks: Cars must be equipped with safety tanks in compliance with the specifications FIA/Spec/FT3 or FIA/Spec/FTA, in the conditions of Art 272 h. The location of the fuel tank is free on condition that it is placed neither in

the cockpit nor in the engine compartment, except if that is the homologated location.

Cutting through the flooring to install a tank is permitted.

Safety tanks are optional in:

—Hill climbs, if total fuel tank capacity is not greater than 20 litres, and if no tank is located more than 30 cm from the car's longitudinal centre line.

—Circuit races in one or several heats of less than 100 km.

Should a safety tank not be used, a real fuel tank must be used.

l) Aerodynamic devices: Seen from above, aerodynamic devices need not follow the contour of the shape of the car. Those which are not homologated for series-production must fit within the car's frontal projection.

In the front: They may not exceed by more than 10% the wheelbase of the car (measurement made from the overall limit of the coachwork) and they may in no case exceed by 20 cm the overall limits of the original bodywork (Art 269 b); they will compulsorily be installed below the horizontal plane passing through the wheel hub and may be inscribed between the lowest suspended part and the ground.

In the rear: They may not exceed by more than 20% the wheelbase of the car (measurement made from the overall limit of the coachwork) and they may in no case exceed by 40 cm the overall limits of the original bodywork (Art 269 b).

TWO-SEATER RACING CARS (Group 6)

Art 270 — Definition: Two-seater competition cars built specially for speed races on closed circuit.

Art 271 — General specifications: These cars should answer the General Prescriptions concerning cars of Groups 1 to 6 (see Art 252 and 255) except as regards the following points:

- The space for the luggage is optional (Art 255 f).
- The spare-wheel is optional (Art 255 i).
- In the case of an open car, the windscreen as well as all the transparent parts of the doors, if provided, are optional and their dimensions free.
- Doors are optional. In case they should be fitted, they should have the dimensions foreseen by Art 255 e).

Art 272 — Supplementary specifications:

a) Minimum weight: Cars should weigh at least the following weights:

Cylinder-capacity inferior or equal to	1,000 cc:	500 kg
„ „ from	1,000 to	1,300 cc: 535 kg
„ „ „	1,300 to	1,600 cc: 560 kg
„ „ „	1,600 to	2,000 cc: 600 kg
„ „ „	2,000 to	3,000 cc: 700 kg
„ „ „	3,000 to	4,000 cc: 765 kg
„ „ „	4,000 to	5,000 cc: 810 kg
„ „ „	5,000 to	6,000 cc: 840 kg
„ „ „	over 6,000 cc:	850 kg

b) Battery: The location of the battery is free. However, it should be firmly secured and entirely protected by a box of insulating material.

c) Wheels and tyres: The number of wheels is limited to four. It is recommended to use wheels including a device to retain the tyres. In case 'knock-off' wheel bolts (butterfly type) are used, the latter should never project beyond the rims.

The maximum width of the complete wheel is limited to 16".

d) Brakes: The braking system should be conceived so that the pedal normally controls all the wheels. In case of a leakage at any point of the brake system pipes or of any kind of failure in the brake transmission system, the pedal shall still control at least two wheels.

e) Suspension elements: It is forbidden to chrome steel suspension elements if they have a rupture resistance superior to 45 tons/sq inch.

f) Coachwork: Coachwork shall provide comfort and safety for driver and a passenger. All elements of the coachwork shall be completely and neatly designed and finished with no temporary or makeshift elements. The body shall cover all mechanical components, except that the intake and exhaust pipes and the upper part of the engine may protrude.

f1) Dimensions: Maximum overall width: 200 cm; maximum overall length: 450 cm.

Height: Open cars: No part of the coachwork, with the exception of the safety roll bar shall exceed in height a horizontal plane 80 cm above the lowest point of the entirely sprung structure of the car.

Height: Closed cars: Maximum height: 110 cm. (Same measurement method as for open cars.)

Air boxes (open and closed cars): No orifice related to the functioning of the engine may exceed in height a plane situated 80 cm above the lowest part of the entirely sprung structure of the car.

f2) Wings: They shall project over the wheels and provide efficient covering of at least 1/3 of their circumference, and at least the width of the tyre wheel. At the rear part of the car, wings should be lower as the axle of the rear wheels. Cooling holes may be provided between the wings and the body.

Cooling holes directed to the rear must be fitted with louvres, baffles or any other device preventing to see the tyre from the rear.

f3) Opening of the cockpit: In an open car, the opening defining the cockpit should be symmetrical about the longitudinal axis of the car.

f4) Visibility: Coachwork shall provide visibility for driver and passenger forward and to both sides adequate for racing conditions. Rear view mirror(s) shall provide driver visibility to the rear on both sides of the car.

f5) Cockpits and seats: The dimensions of the cockpit should correspond to those provided for in Art 255 b) for two-seater cars. The seats for the driver and the passenger should be of similar dimensions and equally disposed on each side of the longitudinal axis of the car. Seats shall be firmly attached in the car, but may provide for adjustment for the size of the occupant.

g) Lighting equipment: The vehicles will be equipped at the rear with at least two braking-lights, as well as two rear red lights both of them being fitted with a minimum 15 w bulb. They will be disposed in a noticeable manner and symmetrically about the longitudinal axis of the car.

For night racing they will be equipped with at least two headlights as effective as those normally fitted on touring cars and two direction indicators

mounted at the rear. The supplementary regulations of an event may require additional lighting and/or signalling equipment.

h) Fuel tanks: All the cars which participate in speed races on circuit consisting of one or several heats of 100 km minimum should be equipped with safety fuel tanks conforming to the specifications FIA/Spec/FT3 or FTA and supplied by an approved manufacturer. Fuel tanks, filled with safety foam complying with the American military specifications Mil-B-83054 (Baffle material), will compulsorily be placed inside the main structure of the car. The fuel system should be so arranged as no part of it is the first object to be struck in an accident. If the car is equipped with a standardised refuelling system, the coupling on the car should be protected.

For hill-climbs, if the total capacity of the fuel tank(s) does not exceed 20 litres a safety bladder tank is no longer mandatory providing that no part of the tank exceeds 30 cm on either side of the longitudinal axis of the car and that it is surrounded by a 1 cm thick crushable structure.

Should a safety tank not be used, a real fuel tank must be used.

i) Fuel tank capacity: The total capacity of the fuel tanks must not exceed the following limits:

Cars up to and equal to	700 cc	engine cylinder-capacity:	60 l
„ from	700 to 1,000 cc	„ „	70 l
„ „	1,000 to 1,300 cc	„ „	80 l
„ „	1,300 to 1,600 cc	„ „	90 l
„ „	1,600 to 2,000 cc	„ „	100 l
„ „	2,000 to 2,500 cc	„ „	110 l
„ „	over 2,500 cc	„ „	160 l

The total capacity of a fuel tank shall not exceed 80 litres. The fuel system must be arranged not to allow more than 80 litres of fuel to spill in the event of a rupture of the fuel tank.

A collector tank of an 8 litres maximum capacity may be placed outside the main chassis on condition that it be surrounded by an approved 10 mm thick crushable structure.

j) Oil tanks: All storage tanks, situated outside the main structure of the car, must be surrounded by 10 mm thick crushable structure. In any case, no oil storage tank, not located within the main structure, may be situated aft the gear-box or differential-casing.

k) Bulkheads and tanks: No part of any fuel, oil or water tank shall be exposed to any part of the driver and passenger compartment. Fuel tanks shall be vented to prevent the accumulation of toxic fumes and to prevent fumes from passing into the driver or engine compartment. Fuel tanks shall be isolated by means of bulkheads so that in case of spillage, leakage or a failure of the tank, the fuel will not pass into the driver or engine compartment or around any part of the exhaust system.

l) Safety equipment: See Art 253 and 255.

Headrest: Compulsory fitting of a headrest capable of restraining 17 kg under a rearward acceleration of 5g. Its dimensions shall be such that in no case can the driver's head be trapped between the roll-over bar and the headrest itself.

Crushable structure: The entire fuel tank area of the car in direct contact with the open airstream must incorporate a crushable structure conforming to

c) **Wheels and tyres:** It is recommended to use wheels including a device to retain the tyres.

The maximum width of the complete wheel is limited to 16".

d) **Brakes:** The braking system should be conceived so that the pedal normally controls all the wheels. In case of a leakage at any point of the brake system pipes or of any kind of failure in the brake transmission system, the pedal shall still control at least two wheels.

e) **Dimensions:** Maximum width: 210 cm.

Aerodynamic devices: The highest point of any forward facing gap in the coachwork shall not be situated above a horizontal plane, 80 cm above the lowest point of the entirely sprung structure of the car.

The engine air intake is not considered to be part of the coachwork.

f) **Wings:** They shall project over the wheels and provide efficient covering of at least 1/3 of their circumference, and at least the width of the tyre wheel. At the rear part of the car, wings should terminate below the axle line of the rear wheels. Cooling holes may be provided between the wings and the body.

Cooling holes directed to the rear must be fitted with louvres, baffles to prevent the tyre being visible from the rear.

g) **Opening of the cockpit:** In an open car, the opening defining the cockpit should be symmetrical about the longitudinal axis of the car.

h) **Cockpits and seats:** The dimension of the cockpit should correspond to those provided for in Art 255 b) for two-seater cars. The seats for the driver and the passenger should be of similar dimensions and equally disposed on each side of the longitudinal axis of the car. Seats shall be firmly attached in the car, but may provide for adjustment for the size of the occupant.

i) **Lighting equipment:** The vehicles will be equipped at the rear with at least two braking-lights, as well as two rear red lights both of them being fitted with a minimum 15 w bulb. They will be disposed in a noticeable manner and symmetrically about the longitudinal axis of the car.

For night racing, they will be equipped with at least two headlights as effective as those normally fitted on touring cars and two direction indicators mounted at the rear.

j) **Fuel tanks:** All the cars which participate in speed races on circuit consisting of one or several heats of 100 km minimum should be equipped with safety fuel tanks conforming to the specifications FIA/Spec/FT3 or FTA and supplied by an approved manufacturer.

The tanks must be filled with safety foam in conformity with the American military specifications MIL-B-83054 (Baffle material).

For hill climbs: If the fuel capacity does not exceed 20 litres, a safety bladder tank is no longer mandatory for cars competing in hill climbs providing that no part of the tank exceeds 30 cm on either side of the longitudinal axis of the car and that it is surrounded by a 1 cm-thick crushable structure.

Tanks exceeding 20 litres will have to conform to the normal safety regulations of the Group 6.

Bulkheads: Fuel tanks shall be isolated by means of bulkheads so that in case of spillage, leakage or a failure of the tank, the fuel will not pass into the driver or engine compartment or around any part of the exhaust system.

k) **Fuel tank capacity:** The total capacity of the fuel tanks must not exceed

the following limits:

Cars up to and equal to	700 cc	engine cylinder-capacity:	60 l
.. from	700 to 1,000 cc	70 l
.. ..	1,000 to 1,300 cc	80 l
.. ..	1,300 to 1,600 cc	90 l
.. ..	1,600 to 2,000 cc	100 l
.. ..	2,000 to 2,500 cc	110 l
.. ..	over 2,500 cc	160 l

l) **Roll-over bars:** Comply with Art 253 e) Group 6 prescriptions, except as concerns the 92 or 120 cm minimum heights.

m) **Starting of the engines:** The starting of the engines is permitted both on the starting grid and in case of a stop at the pit with the help of a supplementary source of energy which will be temporarily connected to a proper coupling fixed on the car.

SINGLE-SEATER RACING CARS (Groups 7 and 8)

A) Art 274 — International Formula No 1:

Summary

Article 1: Definitions

- 1) Formula One car
- 2) Automobile
- 3) Land vehicle
- 4) Coachwork
- 5) Wheel
- 6) 'Automobile make'
- 7) Event
- 8) Weight
- 9) Racing weight
- 10) Cylinder capacity
- 11) Supercharging

Article 2: Regulations

- 1) Role of the FIA
- 2) Publication date for modifications
- 3) Validity of comparison between conventional and turbine engines
- 4) Dangerous construction
- 5) Permanent compliance with regulations
- 6) Measurements

Article 3: Coachwork and dimensions

- 1) Overall width
- 2) Width ahead of front wheels
- 3) Width between the front wheels and the rear wheels
- 4) Width of the rear wing
- 5) Overhang
- 6) Height
- 7) Aerodynamic devices

Article 4: Weight

- 1) Minimum weight
- 2) Ballast

Article 5: Engine

- 1) Engine with reciprocating pistons—cylinder capacity
- 2) Turbine engines

Article 6: Piping, fuel tanks, cables and electrical equipment

- 1) Fuel capacity
- 2) Fuel tank location
- 3) FTA/FT3 rubber bladders
- 4) Rubber bladder manufacturers
- 5) Printing code of rubber bladders
- 6) Rubber bladder limited period of use
- 7) Fuel fittings
- 8) Connections with the chassis
- 9) Fuel lines
- 10) Cables, fuel lines and electrical equipment
- 11) Reinforced piping
- 12) Crushable structures
- 13) Tank fillers and caps
- 14) Refuelling during the race

Article 7: Oil

- 1) Location—Crushable structure
- 2) Oil lines
- 3) Catch tank
- 4) Part of the car containing oil:
Location
- 5) Oil replenishment

Article 8: Starting

- 1) Starter
- 2) External energy source

Article 9: Reverse gear

Article 10: Brakes

Article 11: Wheels and tyres

- 1) Location
- 2) Dimensions

Article 1: Definitions

1) **Formula One car:** An automobile designed solely for speed races on circuits or closed courses.

2) **Automobile:** A land vehicle running on at least four non-aligned wheels, of which at least two are used for steering and at least two for propulsion.

3) **Land vehicle:** A locomotive device, propelled by its own means, moving by constantly taking real support on the earth's surface, of which the propulsion and steering are under the control of a driver aboard the vehicle.

4) **Coachwork:** All entirely sprung parts of the car licked by the external air stream, except the safety roll-over structures and the parts definitely associated with the mechanical functioning of the engine, transmission and running gear.

The air-box(es) and all radiators shall be considered to be part of the coachwork.

5) **Wheel:** Flange and rim. **Complete wheel:** Flange, rim and tyre.

6) **'Automobile make':** In the case of Formula racing cars, an 'automobile make' is a complete car. When the car manufacturer fits an engine which it does not manufacture, the car shall be considered a hybrid and the name of the engine manufacturer shall be associated with that of the car manufacturer. The name of the car manufacturer must always precede that of the engine manufacturer. Should a hybrid car win a Championship Title Cup or Trophy, this will be granted to the manufacturer of the car.

7) **Event:** An event shall consist of official practice and the race.

8) **Weight:** Is the weight of the car in running order with its normal quantity of lubricants and coolants but without any fuel or driver on board.

9) **Racing weight:** Is the weight of the car in running order with the driver aboard and all fuel tanks full.

10) **Cylinder capacity:** Means the volume swept in the cylinder(s) of the engine by the movement of the piston(s). This volume shall be expressed in

Article 12: Cockpit

- 1) Architecture, access, dimensions
- 2) Rear view mirrors
- 3) Safety belts

Article 13: Safety

- 1) Fire extinguishers
- 2) Life support system
- 3) Master switch
- 4) Red light
- 5) Suspension: Chromium plating
- 6) Magnesium sheet
- 7) Safety structures

Article 14: Fuel

- 1) Commercial fuel
- 2) Air

Article 15: Final text

cubic centimetres. In calculating engine cylinder capacity the number π shall be 3.1416.

1) **Supercharging:** Increasing the weight of the charge of the fuel-air mixture in the combustion chamber (over the weight induced by normal atmospheric pressure, ram effect and dynamic effects in the intake and/or exhaust systems) by any means whatsoever.

The injection of fuel under pressure is not considered to be supercharging.

Article 2: Regulations

1) The following regulations governing the construction of Formula 1 cars listed below are issued by the FIA.

2) Each year in October, the FIA will publish all changes made to these regulations. All such changes will take effect on the third 1st January following their publication unless otherwise agreed between the FIA and all Formula One recognised constructors, in which case the change will take effect on the date agreed.

3) The FISA reserve their right to modify the basis of comparison established between conventional type engines and turbine engines, while giving a previous notice of two years to start from 1st January, following the date on which the decision was made.

4) If an automobile is deemed to be dangerous, it may be excluded by the Sporting Stewards of the Meeting.

5) Automobiles must comply with these regulations in their entirety at all times during an event.

6) All measurements must be made while the car is stationary on a flat horizontal metallised surface.

Article 3: Coachwork and dimensions

1) Overall width of the car including complete wheels shall not exceed 215 cm, with the steered wheels in the straight ahead position.

2) The coachwork ahead of the front wheels may be extended to an overall maximum width of 150 cm. Nevertheless, any part of the coachwork ahead of the front wheels exceeding an overall width of 110 cm shall not extend above the height of the front wheel rims with the driver aboard seated normally and irrespective of the fuel load.

3) The overall maximum width of the coachwork behind the forward edge of the front wheels and in front of the centre-line of the rear wheels shall not exceed 140 cm. The crushable structure is included in this width.

4) Coachwork behind the centre-line of the rear wheels shall not exceed 110 cm in width.

5) Except in the case of front-wheel drive when the measurement will be taken from the centre-line of the rearmost substantial load-carrying wheels, no part of the car shall be more than 80 cm behind the centre-line of the rearmost driving wheels. No part of the car shall be more than 120 cm in front of the centre-line of the foremost front wheels. The centre-line of any wheel shall be deemed to be half way between two straight edges, perpendicular to the surface on which the car is standing, placed against opposite sides of the complete wheel at the centre of the tyre tread.

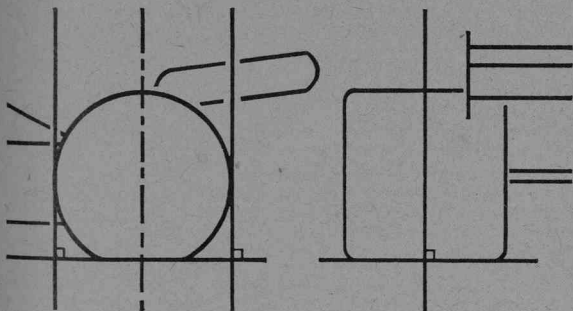

Drawing No 15: Art 3.5. — Wheel centre-line determination.

6) **Height:** Except for the safety roll-over structures no part of the car shall be higher than 90 cm from the ground with the car in normal racing trim with the driver aboard seated normally.

Any part of any safety roll-over structure higher than 90 cm from the ground must not be shaped to have a significant aerodynamic influence on the performance of the car.

7) Any specific part of the car influencing its aerodynamic performance:

- must comply with rules relating with coachwork;
- must be rigidly secured to the entirely sprung part of the car;
- must remain immobile in relation to the vehicle.

Any device bridging the space between the bodywork and the ground is prohibited. Under no circumstances shall any suspended part of the car be less than 6 cm from the ground, with the car in its normal racing trim, the driver on board. Apart from the wheels, no part of the car shall systematically and permanently touch the ground, at any moment, when the car is in motion.

No entirely sprung part of the car shall touch the ground when two tyres situated on the same side are deflated.

If corrections of suspension height can be made with the car in motion, the conditions defined above must be respected with the adjustment at the lowest static position usable in racing.

Article 4: Weight

- 1) The weight of the car must not be less than 585 kg.
- 2) Ballast can be used provided it is secured in such way that tools are required for its removal. It must be possible to fix seals if deemed necessary by the scrutineers.

Article 5: Engine

4-stroke engines with reciprocating pistons:

- a) engine cylinder-capacity without supercharging: inferior or equal to 3000 cc.

Art 274: Formula 1

- b) engine cylinder-capacity with supercharging: inferior or equal to 1500 cc.
Number of cylinders: maximum 12.
The Wankel, Diesel, 2-strokes engines and the turbines are forbidden.

Article 6: Piping and petrol tanks, cables and electrical equipment

- 1) The total capacity of the fuel tanks shall not exceed 250 litres.
- 2) All fuel tanks must be situated within the main structure of the car.
- 3) All fuel tanks, except for a collector tank not exceeding 5 litres capacity, must be rubber bladders conforming to or exceeding the specifications of FIA/Spec/FT3.
- 4) All rubber bladders must be made by manufacturers recognised by the FIA. (In order to obtain the FIA's agreement a manufacturer must prove the compliance of its product with the specifications approved by the FIA. These manufacturers must undertake to deliver to their customers exclusively tanks complying with the norms approved.)

List of recognised manufacturers

Federal Republic of Germany

Uniroyal, 5100 Aachen, Postfach 410.

United States

Don Allen Inc, 401 Agee Road, Grants Has, Oregon 97526.

Aero Tec Labs, Hewson Avenue, Warcick, NJ 07463.

Fuel Safe Corporation, 15545 Computer Lane, Huntingdon Beach, California 92649.

Goodyear Fuel Cell Labs, The Goodyear Tire and Rubber Company, Akron, Ohio 44316.

France

Kléber-Colombes Division Tissus Enduits et Applications, 4 rue Lesage Maille, 76 230 Caudebec-les-Elbeuf.

Ets J. RICHE-BP 14-14690 Pont-d'Ouilly.

Superflexit SA, 45 rue des Minimes, 92-Courbevoile.

Great Britain

FTP Industries Ltd, The Airport, Portsmouth, Hants.

Marston Excelsior Ltd, Wobaston Rd, Wolverhampton, Staffs.

Premier Fuel Systems Ltd, Burnaston Old Airfield, Burnaston, Derby.

Woodville Rubber Company Ltd, Hearthcote Road, Swadlincote, Burton-on-Trent, DE11 9DX.

Italy

Aurodelta SpA (Alfa Romeo), Via Enrico Fermi 7, 20019 Settimo-Milanese.

Pirelli, Viale Rodi 15, Milano.

Japan

Kojima Press Ltd, 3-30 Shimolchibacho Toyota, Aichiken.

Sakura Rubber Co Ltd, 48-14-1 Chome Sasazuka, Shibuya Ku, Tokyo.

Sumitomo Electric Industries Ltd, 15-5 Chome Katahama, Migashi Ku, Osaka.

- 5) All rubber bladders shall have a printed code indicating the name of the manufacturer, the specifications to which the tank has been manufactured and the date of manufacture.

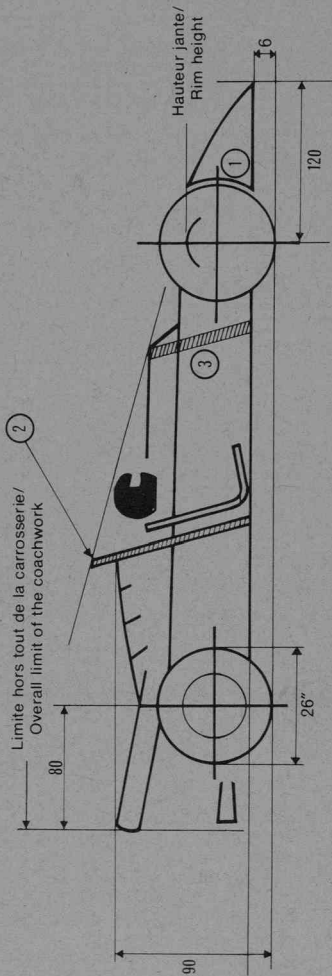

1 — Pour toute partie de plus de 110 de large/For all parts wider than 110

2 — Arceau de sécurité/Safety roll bar

3 — Structure substantielle/Substantial structure

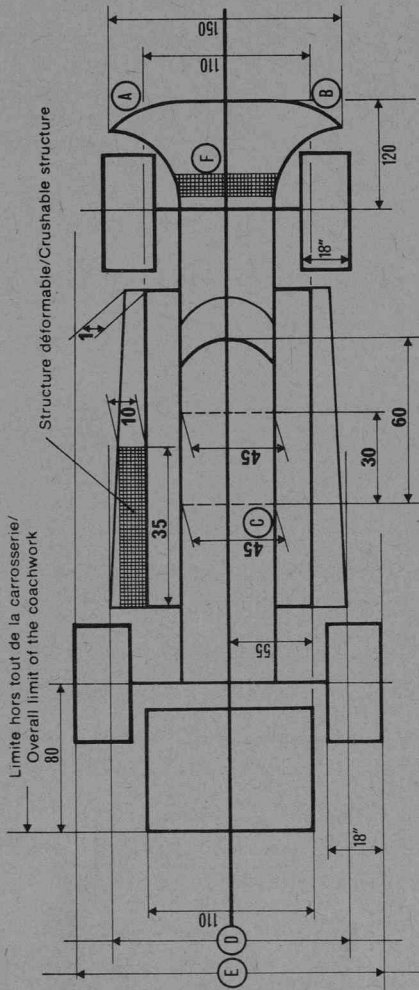

A B — Parties ne devant pas dépasser la hauteur de la jante AV/Parts that must not protrude above level of front rims

C — Point le plus reculé du siège/Most rearward point of seat

D — Largeur maximale: 140 cm/Maximum width: 140 cm

E — Largeur maximale hors tout: 215 cm/Maximum overall width: 215 cm

F — Structure substantielle/Substantial structure

NB: Les chiffres en gras représentent des dimensions minimales/Figures in bold are minimum dimensions

Art 274: Formula 1

6) No rubber bladders shall be used more than five years after the date of manufacture.

7) All fuel fittings (including air vents, inlets, outlets, tank fillers, inter tank connectors and access openings) must be metal fittings bonded into the fuel tank.

8) All connections between any fuel tank and the chassis (including tank fillers, air vents, access openings, inlets and outlets) must be frangible. By frangible is meant that should the fuel tank move relative to the chassis during an accident the connection between the fuel tank and the chassis will fail at a load which is less than 50 per cent of the load required to pull the bonded metal fitting out of the tank.

9) All fuel lines between any fuel tank and the engine must have a self-sealing breakaway valve. This valve must separate at less than 50 per cent the load required to fail the fuel line fitting out of the fuel tank.

10) **Cables, lines and electrical equipment:** Except if the cables, lines and electrical equipment are in compliance with the requirements of the aircraft industry as regards their location, material and connections, they must be placed or fitted in such a way that any leakage cannot result in:

—accumulation of liquid in the cockpit.

—contact between liquid and any electrical line or equipment.

Should the cables, lines or electrical equipment pass through or be fitted in the cockpit, they must be fully enclosed in a cover of a liquid-tight and fire-resistant material.

11) All fuel lines external to the cockpit, with the exception of lines permanently mounted on the engine, must be capable of withstanding a pressure of 70 kg/cm² (1000 psi) and a temperature of 260°C (500°F).

12) **Crushable structures:** The entire fuel tank area of the car in direct contact with the open air stream must incorporate a crushable structure which is an integral part of the car conforming to the specifications hereafter.

This area includes the complete external area of the body/monocoque construction irrespective of such added items as water radiators, inlet ducts, windscreens, etc.

a) The crushable structure should be a sandwich construction based on fire-resistant core of a minimum crushing strength of 25 lb/square inch (18 N/cm²). It shall be permitted to pass water pipes through this core, but not fuel, oil or electrical lines.

The sandwich construction must include two sheets of 1.5 mm thickness one of which shall be aluminium alloy sheet having a tensile strength of 14 tons/square inch (225 N/mm²) and minimum elongation of 5 per cent.

b) The minimum thickness of the sandwich construction must be 1 cm. The side of the fore and aft fuel tank area, however, must contain a crushable structure of at least 10 cm thickness at such crushable structure's thickest point, the position of this widest point to be at the constructor's discretion, over a length of at least 35 cm after which it may be gradually reduced to 1 cm.

13) **Tank fillers and caps:** The tank fillers and their caps shall not protrude beyond the coachwork.

The filler shall have a sufficient diameter to allow for the air exhausted at the time of quick refuelling (in particular those done under pressure). Any breather

pipe connecting the tank with the atmosphere shall be designed to avoid liquid leakage when the car is running and its outlet must not be less than 25 cm to the rear of the cockpit.

All filler caps must be designed to ensure an efficient locking action which reduces the risks of an accidental opening following a crash impact or incomplete locking after refuelling.

14) **Refuelling during the race:** In the event that any fuel is added after the race starts, the container from which fuel is being added must have a leak-proof coupling which connects it to the tank filler on the car. The air vent of the container must be fitted with a non-return valve.

Article 7: Oil

1) All oil storage tanks situated outside the main structure of the car must be surrounded by 1 cm thick crushable structure.

No part of the car containing oil may be situated aft of the gearbox or final drive casing on any rear wheel driven car. In case of front wheel drive, no part containing oil may be situated behind the complete rear wheels.

2) All oil lines external to the cockpit, with the exception of lines permanently mounted on the engine, must be capable of withstanding a pressure of 70 kg/cm² (1000 psi) and a temperature of 260°C (500°F).

3) **Oil catch tank:** When a car's lubrication system includes an open type sump breather, this breather must vent into a catch tank of at least 3 l capacity.

4) No part of the car containing oil may be more than 70 cm from the longitudinal centre-line of the car.

5) No oil replenishment is allowed during a race.

Article 8: Starting

1) A starter and source of energy capable of starting the engine at least twice and operable by the driver when seated normally in the car must be carried aboard the car throughout the event.

2) A supplementary external source of energy temporarily connected to the car may be used to start the engine both to the starting grid and in the pits.

Article 9: Reverse gear

All vehicles must have a reverse gear which must be in working order when the car starts the event and which can be operated by the driver when seated normally in the car.

Article 10: Brakes

All cars must have a brake system which has at least two separate circuits operated by the same pedal. This system must be designed so that if leakage or failure occurs in one circuit, the pedal shall still operate the brakes on at least two wheels.

Article 11: Wheels and tyres

1) Wheels shall be external to the coachwork with the car viewed in plan with the rear aerodynamic device removed.

2) The maximum tyre width is 18 inches and its maximum diameter is 26 inches. The rim is free.

These measurements will be taken with the wheels removed from the car.

Article 12: Cockpit

1) The opening giving access to the cockpit must have the following minimum dimensions:

—length: 60 cm

—width: 45 cm, maintained over 30 cm from the most rearward point of the seat-backrest towards the front.

The driver must be able to enter and get out of his seat without it being necessary to open a door or move any part of the car. Sitting at his steering wheel the driver must be facing forward.

The cockpit must be so conceived that the maximum time necessary for the driver to get out does not exceed 5 seconds with steering wheel in place.

2) All cars must have at least two mirrors mounted so that the driver has visibility to the rear on both sides of the car.

3) **Safety belts:** The wearing of two shoulder straps, one abdominal strap and two straps between the legs is mandatory. These straps must be securely fixed to the car.

Article 13: Safety

1) Fire extinguishers:

a) **Extinguishing product:** BCF (CF₂ Cl Br)—BTM (CBr F₃)—TDE (C₂ Br₂ F₄).

b) Minimum capacity:

Drivers compartment: 5 kg.

Engine compartment: 2.5 kg.

c) **Location—Mounting method:** The extinguisher bottle must be adequately protected and the bottle for the driver's compartment must be mounted within the main structure of the car. In all cases the bottle mountings must be able to withstand a 25 g acceleration.

d) Discharge time:

Engine compartment: 10 seconds minimum.

Driver's compartment: 30 ± 5 seconds for BCF and TDE. 60 ± 5 seconds for BTM.

Both bottles should be released simultaneously.

e) **Drive system:** Any triggering system having its own source of energy is permitted provided it is possible to operate all extinguishers in case the main electric circuits of the car fail. The driver must be able to trigger all extinguishers when seated normally in the car with his safety belts fastened and steering wheel in place.

f) **Checking of bottles:** The following weights shall be indicated on each bottle: weight of the empty bottle; weight of the extinguishing agent; total charged weight.

g) **Operation:** The system must work in any position, even when the car is inverted.

2) **Life support system:** A life support system composed of a medical air bottle connected to the driver's helmet by a flame-resistant pipe must be fitted to the car and connected to the driver's helmet at all times.

3) **Master-switch:** The driver seated normally with his safety belt fastened and the steering wheel in place must be able to cut off all electrical circuits by means of a spark proof circuit breaker. There must also be a clearly indicated external handle which rescue personnel can operate at a distance by a hook. This handle must be located near the base of the main roll-over bar structure and be marked by a symbol showing a red spark in a white-edged blue triangle with a base of at least 10 cm.

4) All cars must have a red warning light of at least 15 watts in working order at the start of a race which: faces rearward, is clearly visible from the rear, is mounted not more than 10 cm from the car centre-line, has a minimum surface of 20 cm², a maximum surface of 40 cm², and can be switched on by the driver.

5) Chromium plating of steel suspension members of over 45 tons/inch² (725 N/mm²) tensile strength is forbidden.

6) The use of magnesium sheet less than 3 mm thick is forbidden.

7) **Safety structures;**

a) The basic purpose of safety structures is to protect the driver. This purpose is the primary design consideration.

b) All cars must have at least two roll-over structures:

i) The first roll-over structure must be in front of the steering wheel, not more than 25 cm forward of the steering wheel rim and at least as high as the top of the steering wheel rim.

ii) The second roll-over structure must be not less than 50 cm behind the first and high enough for a line extended from the top of the first structure to the top of the second to pass over the driver's helmet when he is seated normally in the car with his helmet on and seat belts fastened. If the second structure is not located behind the driver, there must be a structure behind him which is high enough so that a line extended from its top to the top of either structure in front of him will pass over the top of his helmet when he is seated normally with his helmet on and seat belts fastened.

c) All safety structures required by paragraph b must be capable of withstanding three loads applied simultaneously to the top of the structure which are 1.5 w laterally, 5.5 w longitudinally, and 7.5 w vertically, w being the racing weight of the car.

d) The design concept of the safety structures required by paragraph b shall be free. Forward facing stays which restrict the dimensions of cockpit access required by Article 12, paragraph 1, are permitted provided the driver can exit the cockpit in the time required in that paragraph.

e) All cars must have a structure immediately behind the driver's seat which is wider than and extends above his shoulders when he is seated normally in the car with his seat belts fastened. This structure must be capable of withstanding a sustained lateral load of 1.5 w applied to its top, w the racing weight of the car.

f) The chassis shall include an impact absorbing structure (which may be attached) ahead the driver's feet.

It shall be an extension of all the skins of the main chassis construction to a point at least 30 cm ahead of the soles of the driver's feet when normally resting on the pedals in the inoperative position.

At this point 30 cm ahead of the driver's feet it shall have a cross section of at least 200 cm².

Material and thickness will be the same as the corresponding skins of the main chassis structure. The cross section of the material will be at least 3 cm² in non stabilised material and 1.5 cm² in stabilised material.

Holes or cutouts must be strongly reinforced to maintain the cross section of any wall of this base over more than 50%.

This structure may not be an integral part of the chassis, but must be solidly fixed to it.

The chassis must incorporate at least one transversal hoop at the rollbar level, one at the steering wheel level, and one in the area of the pedal box to protect the pedals.

F1) The regulations below (compulsory as from 1.1.82) may be applied by the Constructors from 1981 and in this case they replace the regulations laid out in f):

Survival cell:

1) The chassis structure shall include two continuous box members, one on each side of the driver.

Art 274: Formula 1

2) Each box member shall extend from behind the driver to a point 30 cm in front of the soles of his feet with the drivers seated normally and with his feet on the pedals and the pedals in the inoperative position.

3) Throughout its length the structural material in the cross section of each box member shall have a minimum area of 10 cm^2 , a minimum tensile strength of 31 Kg/mm^2 and a minimum panel thickness of 1 mm on unstabilised skins or 5 cm^2 area and 0.5 mm thickness on stabilised skins.

4) Throughout its length from behind the driver to the soles of his feet each box must have a minimum cross sectional area of 150 cm^2 . Forward of this the boxes may taper to a minimum cross section of 100 cm^2 and a minimal structural material cross section of 5 cm^2 for unstabilised skins or 2.5 cm^2 with stabilised skins.

5) All holes and cutouts in the boxes shall be strongly reinforced and all material sections through these holes shall comply with a minimum area requirement of 10 cm^2 for unstabilised and 5 cm^2 for stabilised skins.

6) The internal cross sectional area of the cockpit from the soles of the driver's feet to behind his seat shall nowhere be less than 700 cm^2 and the minimum width must be 25 cm over the whole length of the cockpit.

7) The minimum height of the box between the front and rear roll-over bar structures shall be no less than 30 cm.

g) All cars must have a headrest which does not deflect more than 5 cm rearwards when a rearward force of 85 kg is applied. It must be designed so that the driver's head cannot be trapped between the roll-over structure and the headrest.

h) Panels at least 20 cm high and of a length of at least 60% of the wheel-base, shall be situated between the front and rear wheels at least 55 cm from the car's axis.

These panels shall be made from a composite material at least 10 mm thick with a honeycomb core in metal or nomex with expanding foam giving adequate resistance to compression. The external covering shall be in aluminium alloy, plastic, or carbon fibre of minimum thickness of 0.5 mm, or in another assembly of materials of equivalent efficiency.

The panels shall be linked transversally to the tub by a series of structural struts ensuring the absorption of a lateral impact. The radiators may play the role of the protective panels or of the transversal struts.

Article 14: Fuel

1) The only fuel permitted is petrol having the following characteristics:

—a maximum of 102 RON, the measurement being made according to the standard ASTM D 2699, the fuel being accepted or rejected according to ASTM D 3244 with a confidence limit of 95%; and

—a maximum of 2% oxygen and 1% nitrogen by weight, the remainder of the fuel consisting exclusively of hydrocarbons and not containing any alcohols, nitro-compounds or other power boosting additives.

In countries where no fuel suitable for use in current F1 engines is commercially available and where the laws of the country prohibit importation of such fuel, the ASN must obtain a dispensation from the FISA for the use of aviation fuel which will then be supplied by the organiser and must be used by all competitors.

2) Only air may be mixed with the fuel as an oxydant.

Article 15: Final text

The final text for these regulations shall be the English version which will be used should any dispute arise over their interpretation.

B) Art 275 — International Formula No 2/No 3:

Summary

Article 1: Definitions

- 1) Formula 2 and 3
- 2) Automobile
- 3) Land vehicle
- 4) Coachwork
- 5) Aerodynamic device
- 6) Wheel
- 7) 'Automobile make'
- 8) Event
- 9) Weight
- 10) Racing weight
- 11) Cylinder capacity
- 12) Supercharging
- 13) Induction system

Article 2: Regulations

- 1) Role of the FIA
- 2) Publication date for modifications
- 3) Previous notice for change in the throttling flange (F3)
- 4) Dangerous construction
- 5) Permanent compliance with regulations
- 6) Measurements

Article 3: Coachwork and regulations

- 1) Overall width
- 2) Width ahead of front wheels
- 3) Width between the front wheels and the rear wheels
- 4) Width of the rear wing
- 5) Overhang
- 6) Height
- 7) Wheel base and track
- 8) Aerodynamic devices

Article 4: Weight

- 1) Minimum weight
- 2) Ballast

Article 5 a): Engine

- 1) Engine with reciprocating pistons
- 2) Wankel engines (F3)
- 3) Engine modifications
- 4) Induction system control
- 5) Exhaust pipes

Article 5 b): Transmission

- 1) Number of gearbox ratios
- 2) Number of driving wheels

Article 6: Fuel, lines and tanks, cables and electrical equipment

- 1) Cables, fuel lines and electrical equipment
- 2) Reinforced piping
- 3) FTA/FT3 rubber bladders
- 4) Crushable structures
- 5) Tank fillers and caps
- 6) Refuelling during the race

Article 7: Oil and water

- 1) Location—crushable structure
- 2) Oil lines
- 3) Catch tank
- 4) Oil replenishment

Article 8: Starting

- 1) Starter
- 2) External energy source

Article 9: Reverse gear

Article 10: Brakes

Article 11: Wheels and tyres

- 1) Number of wheels
- 2) Location
- 3) Dimensions

Article 12: Cockpit

- 1) Architectural access, dimensions
- 2) Rear-view mirrors
- 3) Safety belts

Article 13: Safety

- 1) Fire extinguishers
- 2) Life support system (F2)
- 3) Master switch
- 4) Red light
- 5) Safety structures
- 6) Headrest
- 7) Chromium plating of suspension
- 8) Magnesium sheet
- 9) Titanium use

Article 14: Fuel

- 1) Commercial fuel
- 2) Air

Article 15: Final text

Article 1: Definitions

- 1) **Formula 2 and 3 cars:** A four-wheel automobile designed solely for speed races on circuits or closed courses.
- 2) **Automobile:** A land vehicle running on at least four non-aligned wheels, of which at least two are used for steering, and at least two for propulsion.
- 3) **Land vehicle:** A locomotive device, propelled by its own means, moving by constantly taking real support on the earth's surface, of which the propulsion and steering are under the control of a driver aboard the vehicle.
- 4) **Coachwork:** All entirely sprung parts of the car licked by the external air stream, except the safety roll-over structures and the parts definitely associated with the mechanical functioning of the engine, transmission and running gear. The radiators shall be considered to be part of the coachwork.
- 5) **Aerodynamic device:** Any part of the car whose primary function is to influence aerodynamic performance.
- 6) **Wheel:** Flange and rim. **Complete wheel:** Flange, rim and tyre.
- 7) **'Automobile make':** In the case of Formula racing cars, an 'automobile make' is a complete car. When the car manufacturer fits an engine which it does not manufacture, the car shall be considered a hybrid and the name of the engine manufacturer shall be associated with that of the car manufacturer. The name of the car manufacturer must always precede that of the engine manufacturer. Should a hybrid car win a Championship Title Cup or Trophy, this will be granted to the manufacturer of the car.
- 8) **Event:** An event shall consist of official practice and the race.
- 9) **Weight:** is the weight of the car in running order with its normal quantity of lubricants and coolants, but without any fuel or driver on board.
- 10) **Racing weight:** Is the weight of the car in running order with the driver aboard and all fuel tanks full.
- 11) **Cylinder capacity:** Means the volume swept in the cylinder(s) of the engine by the movement of the piston(s). This volume shall be expressed in cubic centimetres. In calculating engine cylinder capacity, the number π shall be 3.1416.
- 12) **Supercharging:** Increasing the weight of the charge of the fuel-air mixture in the combustion chamber (over the weight induced by normal atmospheric pressure, ram effect and dynamic effects in the intake and/or exhaust systems) by any means whatsoever. This injection of fuel under pressure is not considered to be supercharging.
- 13) **Inlet system:** All the elements of the inlet system included between the head and external side of the throttling flange.

Article 2: Regulations

- 1) The following regulations governing the construction of F2 and F3 cars listed below are issued by the FIA.
 - 2) Each year, the FIA will publish all changes made to these regulations. All such changes will take effect on the third 1st January following their publication.
- Changes made in consideration of safety matters may come under validity immediately.

- 3) The FISA reserves its right in F3 to modify the dimensions of the throttling flange with a shorter previous notice than the two regular years.
- 4) If an automobile is deemed to be dangerous, it may be excluded by the Sporting Stewards of the Meeting.
- 5) Automobiles must comply with these regulations in their entirety at all times during an event.
- 6) All measurements must be made while the car is stationary on a flat horizontal metallised surface.

Article 3: Coachwork and dimensions

1) Overall width of the car, including complete wheels with the steered wheels in the straight ahead position, shall not exceed: F2—200 cm; F3—185 cm.

2) The coachwork ahead of the front wheels may be extended to an overall maximum width of: F2—150 cm; F3—135 cm.

Nevertheless, any part of the coachwork ahead of the front wheels exceeding an overall width of: F2—110 cm; F3—95 cm, shall not extend above the height of the front wheel rims, with the driver aboard seated normally, and irrespective of the fuel load.

3) The overall maximum width of the coachwork behind the forward edge of the front wheels and in front of the centre-line of the rear wheels shall not exceed 130 cm.

The crushable structure is included in this width.

4) Coachwork behind the centre-line of the rear wheels shall not exceed in width: F2—110 cm; F3—95 cm.

5) Except in the case of front-wheel drive when the measurement will be taken from the centre-line of the rearmost substantial load carrying wheels, no part of the car shall be more than 80 cm behind the centre-line of the rearmost driving wheels.

No part of the car shall be more than 100 cm in front of the centre-line of the foremost front wheels.

The centre-line of any wheel shall be deemed to be half way between two straight edges, perpendicular to the surface on which the car is standing, placed against opposite sides of the complete wheel at the centre of the tyre tread.

6) **Height:** Except for the safety roll-over bars, no part of the car shall be higher than 90 cm from the ground with the car in normal racing trim with the driver aboard seated normally.

Any part of any safety roll-over bar higher than 90 cm from the ground must not be shaped to have a significant aerodynamic influence on the performance of the car.

7) For F3:

Minimum wheelbase: 200 cm

Minimum track: 120 cm

8) Aerodynamic devices must comply with the rules relating to coachwork, and must be firmly secured whilst the car is in motion. Under no circumstances can any part of the bodywork or of the suspended part of the car be below a

horizontal plane passing 1 cm under the bottom of the driver's seat and at least 4 cm above the ground, the car being in normal racing trim with the driver on board. In order to allow the scrutineers to carry out this check a 10 mm diameter hole will be bored through the bottom of the seat and the corresponding floor.

Article 4: Weight

- 1) The weight of the car must not be less than: F2—515 kg; F3—455 kg.
- 2) Ballast can be used provided it is secured in such way that tools are required for its removal. It must be possible to fix seals if deemed necessary by the scrutineers.

Article 5a: Engine

1) Engines with reciprocating pistons:

Engine cylinder capacity: inferior or equal to 2,000 cm³.

Maximum number of cylinders: F2—6; F3—4.

Supercharging is forbidden.

2) For F3 only:

Rotary piston engines: Cars with rotary piston engines covered by the NSU—Wankel patents will be admitted on the basis of a piston displacement equivalence. This equivalence is twice the volume determined by the difference between the maximum and minimum capacity of the working-chamber.

3) For F3 only:

The engine block and engine head castings, machining completed, must be those of an engine equipping a car model of which the FIA has ascertained the series-production of at least 5,000 units in 12 consecutive months. The original engine block and cylinder head may be modified freely by removal of material to the exclusion of any addition of material. However, it is permitted to sleeve an engine block that originally is not fitted with sleeves.

The type of crankshaft bearings may not be modified (the replacement of a plain bearing by a roller bearing is therefore forbidden).

It is pointed out that whatever the type of the engine used, it is not compulsory that the different mechanical components of the engine should proceed from the original engine.

The induction system is free but it must be fitted with a throttling flange of 3 mm in length having a circular section, and with a parallel hole of 24 mm diameter maximum. All the air feeding the engine must pass through this throttling flange, which must be made of metal or metal alloy.

The material of the air box is free, provided that it is not porous.

It is prescribed that the entire inlet system including manifolds, injectors, air-box and restrictor must fit into a box of 1 m long, 50 cm wide and 50 cm high. It will also be prescribed that the inlet system may be removed from the engine as one unit with the cylinder head(s).

The maximum cylinder-capacity may be obtained by increasing or reducing either the bore or stroke or both dimensions.

The other original parts of the engine may be replaced or modified without restriction. It is permitted to weld the sleeves to the block for the conventional engine.

For F2: Free.

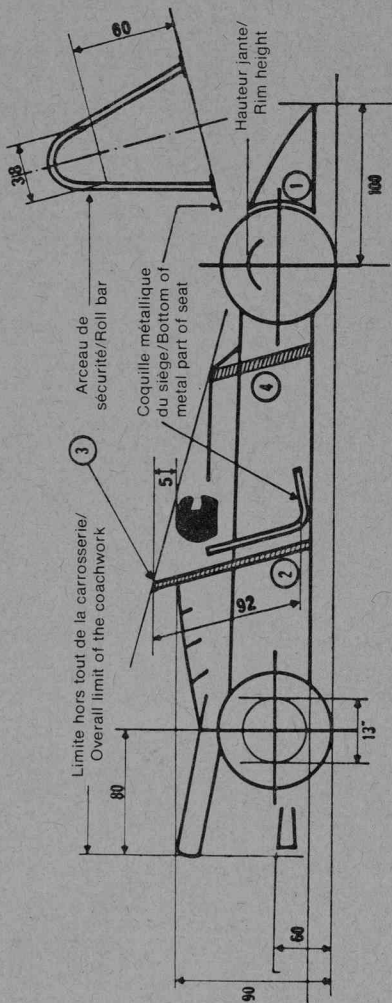

- 1 — Pour toute partie de plus de 110 de large/For all parts wider than 110
- 2 — Fond de la coque de métal du siège/Bottom of the metal part of the seat
- 3 — Arceau de sécurité/Safety roll bar
- 4 — Structure substantielle/Substantial structure

4) **For F3 only:**

Vacuum tightness control apparatus of the induction system for F3 engines: The control apparatus described hereafter represents the ultimate method of verification of the vacuum tightness of F3 induction systems, without the possibility of appeal. All F3 event organisers will have to put such an apparatus at the disposal of the scrutineers for verification purposes, both before and after the race.

The apparatus aims to create artificially a vacuum in the induction system and includes:

—A membrane suction-pump, with the nominal output of 25 to 28 litres/minute, and capable of obtaining a vacuum of 55 to 65 cm Hg for zero air flow.

—A rubber tubular stop perfectly adjusted to the flange.

—A vacuum-gauge connected to the piping between the rubber stop and the suction-pump.

The procedure to be respected for the checking is the following:

a) Rotate the engine into such a position that, in each cylinder, at least one of the valves is closed.

b) Open the injection slide or the carburettor butterflies.

c) Check on the vacuum-gauge that the suction-pump creates in the induction system a depression superior or equal to 15 cm Hg.

d) If the condition a) cannot be met, disconnect the rocker-arms or remove the camshaft, in order to shut all inlet valves. If one or several valves have been damaged during the event, the entrant may repair them under the steward's control before undergoing the testing procedure. In these last cases, the minimum vacuum to be obtained shall be 20 cm Hg instead of 15.

5) **Exhaust pipes:** The outlet orifices of the exhaust pipes, when directed to the rear, must be placed at a height of less than 60 cm above the ground.

Article 5b: Transmission

1) **F2 only:** Five gearbox ratios, not including the reverse gear, as maximum.

2) The car must be driven by two wheels only.

Article 6: Fuel lines and tanks, cables and electrical equipment

1) Except if the cables, lines and electrical equipment are in compliance with the requirements of the aircraft industry as regards their location, material and connections, they must be placed or fitted in such a way that any leakage cannot result in:

—Accumulation of liquid in the cockpit.

—Contact between liquid and any electrical line or equipment.

Should the cables, lines or electrical equipment pass through or be fitted in the cockpit, they must be fully enclosed in a cover of a liquid-tight and fire-resistant material.

2) All fuel lines external to the cockpit, with the exception of lines permanently mounted on the engine, must be capable of withstanding a temperature of 230°C and a pressure of:

— 70 kg/cm² for those lines working under pressure.

— 7 kg/cm² for others.

3) All fuel tanks, except for a collector tank not exceeding 5 litres capacity, must be rubber bladders conforming to or exceeding the specifications of FIA/Spec/FT3.

a) **Safety fuel tanks approved by the FIA:**

Technical specifications: The FIA reserves its right to approve any other set of technical specifications after study of the dossier submitted by the manufacturers concerned.

b) **Safety tank manufacturers recognised by the FIA:**

Entrants must use safety fuel tanks made by a manufacturer recognised by the FIA. In order to obtain the FIA's agreement, a manufacturer must prove the compliance of its product with the specifications approved by the FIA.

These manufacturers must undertake to deliver to their customers exclusively tanks complying with the norms approved. To this end, on each tank delivered there shall be printed a code indicating the name of the manufacturer, the exact specification according to which this tank has been manufactured and the date of the manufacturing.

c) **Ageing of safety fuel tanks:**

The ageing of safety fuel tanks entails a considerable reduction in the strength characteristics after approximately five years.

Therefore, all fuel cells must be replaced at the latest five years after the date of manufacture indicated on the cell.

d) **List of recognised manufacturers**

Federal Republic of Germany:

Uniroyal, Postfach 410, D-5100 Aachen.

United States:

Don Allen Inc, 401 Agee Road, Grants Has, Oregon 97526.

Aero Tec Labs, Hewson Avenue, Warcick, NJ 07463.

Goodyear Fuel Cell Labs, The Goodyear Tire & Rubber Co. Akron, Ohio 44316.

France:

Kléber Colombes, Division Tissus Enduits et Applications, 4 rue Lesage Maille, 76 230 Caudebec-les-Elbeuf.

Ets J. RICHE-BP 14-14690 Pont-d'Ouilly.

Superflexit SA, 45 rue des Minimes, 92000 Courbevoile.

Great Britain:

FPT Industries Ltd, The Airport, Portsmouth, Hants.

Marston Excelsior Ltd, Wobaston Road, Wolverhampton, Staffs.

Premier Fuel Systems Ltd, Burnaston Old Airfield, Burnaston, Derby.

Woodville Rubber Company Ltd, Hearthcote Road, Swadlincote, Burton-on-Trent, DE11 9DX.

Italy:

Autodelta Spa (Alfa Romeo), Via Enrico Fermi 7, 20019 Settimo-Milanese.

Pirelli, Viale Rodi 15, Milano.

Japan:

Kojima Press Ltd, 3-30 Shimolchibacho Toyota, Aichiken.

Sakura Rubber Co Ltd, 48-14-1 Chome Sasazuka, Shibuya Ku, Tokyo.

Sumitomo Electric Industries Ltd, 15-5 Chome Katahama, Migashi-ku, Osaka.

4) **Crushable structures (for F2 only):** The entire fuel tank area of the car in

direct contact with the open air stream must incorporate a crushable structure which is an integral part of the car conforming to the specifications hereafter.

This area includes the complete external area of the body/monocoque construction irrespective of such added items as water radiators, inlet ducts, windscreens, etc.

a) The crushable structure should be a sandwich construction based on fire resistant core of a minimum crushing strength of 25 lb/square inch (18 N/cm²). It shall be permitted to pass water pipes through this core, but no fuel, oil or electrical lines.

The sandwich construction must include two sheets of 1.5 mm thickness, one of which shall be aluminium, alloy sheet having a minimum tensile strength of 14 tons/square inch (225 N/mm²) and minimum elongation of 5 per cent.

b) The minimum thickness of the sandwich construction must be 1 cm. The side of the fore and aft fuel tank area, however, must contain crushable structure of at least 10 cm thickness at such crushable structure's thickest point, the position of this widest point to be at the constructor's discretion, over a length of at least 35 cm after which it may be gradually reduced to 1 cm.

5) **Tank fillers and caps:** The tank fillers and their caps shall not protrude beyond the coachwork.

The filler shall have a sufficient diameter to allow for the air exhausted at the time of quick refuelling (in particular those done under pressure). Any breather pipe connecting the tank with the atmosphere shall be designed to avoid liquid leakage when the car is running, and its outlet must not be less than 25 cm to the rear of the cockpit.

All filler caps must be designed to ensure an efficient locking action which reduces the risk of an accidental opening following a crash impact or incomplete locking and refuelling.

6) **Refuelling during the race:** In the event that any fuel is added after the race starts, the container from which fuel is being added must have a leak-proof coupling which connects it to the tank filler on the car. The air vent of the container must be fitted with a non-return valve.

Article 7: Oil

1) All oil storage tanks situated outside the main structure of the car must be surrounded by 1 cm thick crushable structure.

No part of the car containing oil may be situated aft of the gearbox, or final drive casing on any rear wheel driven car. In case of front wheel drive, no part containing oil may be situated behind the complete rear wheels.

2) Oil lines external to the cockpit with the exception of lines permanently mounted on the engine, must be a reinforced construction. They must withstand a pressure of 70 kg/cm² (1,000 psi) and a temperature of 230°C.

3) **Oil catch tank:** When a car lubrication system includes an open type sump breather, this breather must vent into a catch tank of at least 2-litre capacity.

The container shall either be made out of translucent plastic, or include a transparent panel.

4) No oil replenishment is allowed during a race.

Article 8: Starting

1) Compulsory starter with electrical or other source of energy carried aboard the car, and able to be controlled by the driver when normally in his seat.

2) A supplementary external source of energy temporarily connected to the car may be used to start the engine, both on the starting grid and in the pits.

Article 9: Reverse Gear

All vehicles must have a reverse gear which must be in working order when the car starts the event, and which can be operated by the driver when seated normally in the car.

Article 10: Brakes

All cars must have a brake system which has at least two separate circuits operated by the same pedal. This system must be designed so that if leakage or failure occurs in one circuit, the pedal shall still operate the brakes on at least two wheels.

Article 11: Wheels and tyres

1) Number of wheels: 4.

2) Wheels shall be external to the coachwork with the car viewed in plan with the rear aerodynamic device removed.

3a) **For F2**, the maximum width of any rim and tyre assembly shall not exceed 16 inches.

Compulsory diameter of the rear wheels: 13".

For F3: The width of the complete wheels is limited to 11.5 inches.

Compulsory diameter of the rear wheels: 13 inches.

b) The width shall be measured with the tyre at normal running pressure, and the complete wheel mounted on the car resting on the ground in running order with the driver aboard.

This measurement of the width will only be taken at the widest point of the tyre, above the hub-level. In no case can the interior width measured where the beads join the rim exceed the width of the tyre.

Article 12: Cockpit

1) The opening giving access to the cockpit must have the following minimum dimensions:

—Length: 60 cm.

—Width: 45 cm, maintained over 30 cm from the most rearward point of the seat-backrest towards the front.

The driver must be able to enter and get out of his seat without it being necessary to open a door or move any part of the car. Sitting at his steering wheel, the driver must be facing forward.

The cockpit must be so conceived that the maximum time necessary for the driver to get out does not exceed five seconds with steering wheel in place.

2) All cars must have at least two mirrors mounted so that the driver has visibility to the rear on both sides of the car: (minimum surface of each one: 55 cm²).

3) **Safety belts**: The wearing of two shoulder straps, one abdominal strap

and two straps between the legs is mandatory. These straps must be securely fixed to the car.

Article 13: Safety

1) Fire Extinguishers — Extinguishing systems

a) **Extinguishant:** Halon 1211 or 1301 (BCF—BTM).

b) **Minimum capacity:**

Cockpit 5 kg

Engine compartment 2.5 kg

c) **Location:**

Mounting method: the extinguisher bottle must be adequately protected, and the bottle for the driver's compartment must be mounted within the main structure of the car. In all cases, the bottle mountings must be able to withstand 25 g accelerations, no matter how these are applied.

d) **Discharge Time:**

Engine compartment: 10 seconds

Driver's compartment: 30 ± 5 seconds for Halon 1211

60 ± 5 seconds for Halon 1301

e) **Drive System:**

Any triggering system having its own source of energy is permitted, provided it is possible to operate all extinguishers in case the main electric circuits of the car fail.

Automatic triggering by heat sensors is recommended, the driver must be able to trigger all extinguishers manually when seated normally in the car with his belts fastened and steering wheel in place, the same applies to any person outside the car. The means of triggering from the exterior must be positioned close to the circuit breaker or combined with it, and must be clearly marked by a red letter 'E' in a white circle of at least 10 cm diameter, with a red edge.

f) **Checking of bottles:**

The type of extinguishant, the total weight of the bottle and the quantity of extinguishant must be specified on each bottle.

g) **Working:**

The two systems must be triggered simultaneously.

Any triggering system is allowed. However a source of energy not coming from the main source must be provided in the case of a triggering system which is not exclusively mechanical.

Concerning triggering in the interior, and to avoid accidental triggering a warning symbol must be fitted.

The system must work in any position even when the car is upside down.

2) **For F2 only:**

Life support system: A life support system composed of a medical air bottle connected to the driver's helmet by a flame-resistant pipe must be fitted to the car and connected to the driver's helmet at all times.

3) **Master-switch:** The driver seated normally with his safety belt fastened and the steering wheel in place must be able to cut off all electrical circuits by means of a spark proof circuit breaker, which will be also accessible from outside the car. As for the outside, the triggering system of the circuit breaker will compulsorily be situated at the lower part of the main hoop of the roll-bar,

indifferently on the right or the left. It will be marked by a red spark in a white-edged blue triangle with a base of at least 10 cm.

4) All cars must have a red warning light of at least 15 watts in working order at the start of a race which faces rearward, is clearly visible from the rear, is mounted not more than 10 cm from the car centre-line, has a minimum surface of 20 cm², a maximum surface of 40 cm², and can be switched on by the driver.

5) **Safety Structures:**

a) All cars must have a substantial structure to protect the driver's feet, which is capable of withstanding a compression load of 25 w applied to the front of the car without allowing the pedals to move rearwards more than 15 cm when the car is at racing weight (w).

b) **Roll-over bars:**

1) The basic purpose of safety structures is to protect the driver. This purpose is the primary design consideration.

2) All cars must have at least two roll-over structures, but the use of titanium is forbidden.

The first roll-over structure must be in front of the steering wheel, not more than 25 cm forward of the steering wheel rim and at least as high as the top of the steering wheel rim.

The second roll-over structure must be not less than 50 cm behind the first. It must be high enough for a line extending from the top of the first structure to the top of the second, to pass over the driver's helmet when he is seated normally in the car with his helmet on and seat belts fastened.

This second structure behind the seat must be symmetrical about the lengthwise centre-line of the car and comply with the following figures:

—The minimum height must be at least 90 cm measured vertically from the base of the monocoque.

—The top of the roll-bar must also be at least 5 cm above the driver's helmet when the driver is sitting in a normal driving position.

Strength: In order to obtain a sufficient strength for the roll-over structures, two possibilities are left to the manufacturers (until 1.1.82):

—The tubes and brace(s) must have a diameter of at least 35 mm and at least 2 mm wall thickness. The material should be molybdenum chromium SAE 4130 or SAE 4125 (or equivalent in DIN, NF, etc). (This possibility will no longer exist as and from 1.1.82).

—The roll-bar, of entirely free structural conception, must be capable of withstanding the stress minima indicated as follows: Applied simultaneously to the top of the structure, which are 1.5 w laterally, 5.5 w longitudinally in both directions and 7.5 w vertically, w being the racing weight of the car, the induced loads being carried over into the primary structure of the chassis.

A certificate signed by a qualified technician must be submitted to the scrutineers of an event. It must be accompanied by a drawing or a photograph of the said roll-bar, and state that this roll-bar can withstand the above mentioned loads.

General considerations:

—Whenever bolts and nuts are used, the bolts should be of a sufficient minimum diameter, according to the number used. They should be of the highest possible quality (preferably aircraft). Square head bolts and nuts should not be used.

—One continuous length of tubing should be used for the main structure with smooth continuous bends and no evidence of crimping or wall failure.

—All welding should be of the highest quality possible with full penetration (preferably arc welding and in particular heliarc).

—For space-frame constructions, it is important that roll-over structures are attached to cars in such a way as to spread the loads over a wide area. It is not sufficient to simply attach the roll-bar to a single tube or junction of tubes. The roll-bar should be designed in such a way as to be an extension of the frame itself, not simply an attachment to the frame.

Considerable care should be attached to the necessary strengthening of the basic structure, for instance by adding reinforcement bars or plates so as to properly distribute the loads.

—For monocoque constructions, consideration should be given to using a roll-bar hoop of 360 degrees completely around the inside of the car, and attached with suitable mounting plates. This type of roll-bar then becomes a substitute for the frame.

6) All cars must have a headrest which does not deflect more than 5 cm rearwards, when a rearward force of 85 kg is applied. It must be designed so that the driver's head cannot be trapped between the roll-over structure and the headrest.

7) **Chromium plating** of steel suspension members of over 45 tons/square inch (725 N/mm^2) tensile strength is forbidden.

8) **The use of magnesium sheet** less than 3 mm thick is forbidden.

9) **The use of titanium** in suspension and steering parts, or in the roll-over structures is forbidden.

Article 14: Fuel

1) In piston engines, the only fuel permitted is petrol having the following characteristics:

a) A maximum of 102 RON, the measurement being made according to the standard ASTM D 2699, the fuel being accepted or rejected according to ASTM D 3244 with a confidence limit of 95%, and

b) A maximum of 2% oxygen and 1% nitrogen by weight, the remainder of the fuel consisting exclusively of hydrocarbons and not containing any alcohols, nitro-compounds or other power boosting additives.

In countries where no fuel suitable for use in current F2/F3 engines is commercially available, and where the laws of the country prohibit importation of such fuel, the ASN must obtain a dispensation from the FISA for the use of aviation fuel which will then be supplied by the organisers and must be used by all competitors.

2) Only air may be mixed with the fuel as an oxydant.

Article 15: Final Text

The final text for these regulations shall be the French version which will be used should any dispute arise over their interpretation.

C) Art 277 — Formule Libre racing cars (Group 8):

It is permitted to organise sporting competitions open to other racing cars than those defined in one of the previous Groups of Appendix J.

All specifications concerning the vehicles and particularly the limitations of the cylinder-capacity are in this case at the discretion of the promoters and it rests with them to list these specifications as clearly as possible in the Sup-

plementary Regulations of the event, which anyway have to be approved by the National Sporting Authority answerable to the FIA.

However, racing cars, which do not comply with any of the International Racing Formulae, must for security reasons be in conformity with the General Prescriptions listed under Art 253 b), c), d), e), f), g), h), i), j), n), o), and Art 274.3.5 (f§).

TITLE 5—NATIONAL FORMULAE

Registration of National Racing Formulae

The FISA will accept to study the registration of 'national' formulae, in order to have their technical prescriptions known at an international level and to ensure a certain stability and a standardisation of the regulations which rule them.

1—In pursuance of Art 253, any ACN has the right to define regulations applying to given types of 'Formula libre' racing cars denominated hereafter: 'National Formulae'.

2—Are eligible for registration only the applications presented by at least 2 National Sporting Authorities and concerning a National Formula used in at least 2 countries.

3—The FIA will accept, in compliance with the preceding Art 2 to register on a voluntary basis any set of prescriptions defining such National Formulae.

The regulations thus registered by the FIA will be applicable in countries, the ACNs of which have declared to abide by them.

The declaration made by the National Sporting Authority to adopt the regulations of a determined National Formula is exclusively valid for the regulations such as they were originally deposited at the FIA, and this National Sporting Authority is entitled to withdraw this declaration if the regulations are altered afterwards.

The withdrawal of a declaration for another reason than the one hereabove mentioned, must compulsorily be communicated to the FIA before December 31st in order to be valid as from the following year.

4—From the time when such a National Formula is registered, its appellation can be used, in those countries where the ACNs have adopted the registered regulations, only for cars entirely complying with the regulations deposited at the FIA.

5—Any application for the registration of regulations for a National Formula should be addressed to the FIA at the latest on October 1st, to be valid as from January 1st of the following year.

The National Formulae can (but it is not compulsory) form the subject of restrictions as regards the engine or other manufacturing elements, in order to allow exclusively the use of castings of a given make. Such a one-make Formula may have a distinct commercial name related to the imposed design restrictions.

6—The National Sporting Authorities which have adopted a determined National Formula may file an application at the FIA in view of the organisation of a reward including several countries.

Any application of that kind will be submitted to the appreciation of the FISA whose decision will depend on the number of countries interested by the organisation of an event included in that reward and on the advisability or the

National Formulae

necessity, for the general interest of Automobile Sport, to introduce such a form of competition.

7—The organisation of any other type of international reward without the FIA's agreement, as prescribed in the above Art 6 will entail the application of penalties.

National Formulae registered by the FIA

	Nation Nazione	Limite de cyl(ccm) Capacity limit (cc) Max. Hubraum (ccm) Cilindrata max (cc)	Moteur dérivé de Engine origin Motorherkunft Motore derivato da	Type de châssis Chassis base Chass Basis Tipo di telaio	Secretariat Head office Hauptbüro Segreteria
F.V.	(D)	1300	VW 1300	VW 1300 Single seater	Formel V Europa E. V. Volkswagen—Motorsport, Ikarusallee 34, D 3000 Hannover 1
F. Super V	(D)	1600	VW 1600	Single seater	Formel V Europa E. V. Volkswagen—Motorsport Ikarusallee 34, D 3000 Hannover 1
F. Ford	(GB)	1600	Cortina GT	Single seater	RAC British Motor Sports Council, 31 Belgrave Square, London SW1X 8QH
F. Renault (F)		1565	Renault Gordini	Single seater	FFSA, 136 rue de Longchamp, Paris 16e
F. Renault Europe (F)		1596	Renault Gordini	Single seater	FFSA, 136 rue de Longchamp, Paris 16e

**Motor sporting officials,
competitors and enthusiasts
buy and read the**

FIA Year Book of Automobile Sport

Why not tell them about *your* company next year?

Contact our advertisement representatives:

Great Britain

Jackson-Rudd and Associates Limited
46/47 Chancery Lane, London WC2A 1JB
(Tel: 01-405 3611)

France

Les Régisseurs Conseils, 45 rue de Lisbonne, 75008 Paris
(Tel: 267.54.43)

Germany

Eddie Guba, RennReport, Linderhofstrasse 16, D-8000 München 70
(Tel: (089) 71 11 71)

Published by



Patrick Stephens Limited

Bar Hill, Cambridge, CB3 8EL. Tel 0954 80010. Telex 817677