

ASSOCIATION INTERNATIONALE
DES
AUTOMOBILE-CLUBS RECONNUS

CODE SPORTIF INTERNATIONAL

ANNEXES

APPENDICES

TO THE
INTERNATIONAL SPORTING CODE



1934

CLASSE	CYLINDRÉE (Cylinder volume)	NOMBRE MINIMUM de places — Minimum number of seats	NOMBRE MINIMUM de personnes — Minimum number of persons
2^o Catégorie Sport (Sport Category)			
A	Au-dessus de (over) 8.000 cc.	2	1
B	— 5.000 cc. et. jusqu'à (up to) 8.000 cc.	2	1
C	— 3.000 cc — 5.000 cc.	2	1
D	— 2.000 cc. — 3.000 cc	2	1
E	— 1.500 cc. — 2.000 cc.	2	1
F	— 1.100 cc. — 1.500 cc.	2	1
G	— 750 cc. — 1.100 cc.	1	1
H	— 500 cc. — 750 cc.	1	1
I	— 350 cc. — 500 cc.	1	1
J	Jusqu'à (up to) 350 cc.	1	1

ANNEXE C

245. Classification des véhicules — (Classification of vehicles)

ARTICLE PREMIER

Records recognised by the A. I. A. C. R. are reserved only for cars described in the table below particularly excluding vehicles propelled by air screws or rockets.

Les records homologués par l'A.I.A.C.R. sont réservés aux véhicules décrits dans ce tableau et à l'exclusion notamment des véhicules propulsés par hélice aérienne ou par fusées.

CLASSE	CYLINDRÉE (Cylinder volume)	NOMBRE MINIMUM de personnes et de places MINIMUM NUMBER of persons and seats
1^o Catégorie Course (Racing Category)		
A	Au-dessus de (over) 8.000 cc.	1
B	5.000 cc. et jusqu'à (up to) 8.000 cc.	1
C	3.000 cc.	1
D	2.000 cc.	1
E	1.500 cc.	1
F	1.100 cc.	1
G	750 cc.	1
H	500 cc.	1
I	350 cc.	1
J	Jusqu'à (up to) 350 cc.	1

ARTICLE 2.

246. **Weight.** — When supplementary regulations stipulate minimum weights for vehicles of the Sport Category, the weight of a vehicle shall be that of all the material and parts which constitute the whole vehicle; consequently the use of *ballast to make up this weight will in no case be allowed.*

Each vehicle shall be weighed with the body-work, and its wheels must be fitted with the pneumatic or other tyres with which it will start; but without water, fuel, tools, lubricant, spare parts, spare wheels or spare tyres.

In order to facilitate the work, the vehicle may be weighed without removing the oil, adding to the minimum weights required by the supplementary regulations the following extra weights :

Classes A and B	20 kgs.
» C and D	15 kgs.
» E, F and G	10 kgs.

ARTICLE 3.

247. **Body.** — For the «Sports» Category, the requirements not specified in table C are as stated hereunder :

Bodies must be completely finished, and must not have any temporary part.

The front seats must fulfil the conditions which are shown in the following diagrams (Fig 1 and 2).

The rear seats are optional, but if the supplementary regulations of any competition specify classes for cars with four seater bodies, the rear seats must conform to the same conditions as the front seats. Further there shall be a horizontal space measured between the back of the front seat and the front edge of the rear cushion which measurement shall not be less than 20 centimetres.

N. B. — During the competition the back of the rear seats may be raised or lowered depending on the requirements contained in the supplementary regulations.

For all cars carrying more than one seat : Internal width of body measured at the height of the seats : 80 cent.

Except for cars in Classes G, H, I, J, which when only required to carry one seat, minimum width of seat : 40 cent.

For all Classes : minimum width to accommodate the legs and feet (for each seat) : 25 centimetres.

a. — Measured horizontally and parallel to the longitudinal axis of the chassis at the level of the floor or of its sunk portion, if any.

For the driver's seat the distance — a — is measured from the perpendicular of the farthest pedal in its position

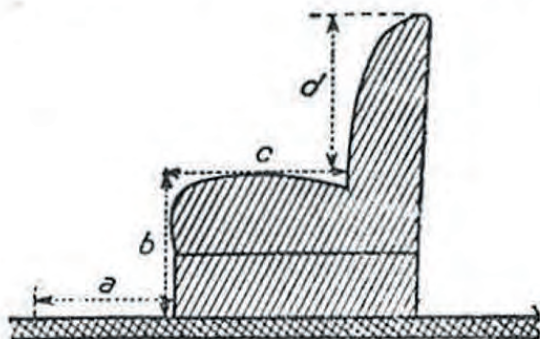

Fig. 1 (Échelle : 1/25)

of rest ; for the seats of the passenger this measurement is taken, at a height of 20 centimetres, between the two extreme front and rear points of the horizontal part of the floor.

In the case of sliding seats it is forbidden to alter the position of any seat while the cars are being measured.

b. — Measured vertically, the seat cushion being occupied by a person weighing at least 60 kgs.

c. — Measured horizontally, parallel to the longitudinal axis of the chassis, and at the middle of each seat in the case of bucket shaped seats.

d. — Measured vertically.

The arrangement of the body must be such that :

$$a + b + c = 1 \text{ metre } 10 \text{ cms at least,}$$

subject to the observance of the following minimum dimensions :

$$a = 30 \text{ centimetres}$$

$$b = 15 \quad \text{—}$$

$$c = 40 \quad \text{—}$$

$$d = 40 \quad \text{—}$$

Examples : a = 50 ; b = 15 ; c = 45. a = 30 ; b = 40 ; c = 40 ; etc.

248. Mudguards. — The mudguards of vehicles shall be situated exactly over the wheels and shall cover them effectively by circumscribing at least one third of their circumference, without any break. The mudguards shall have a minimum width of 15 centimetres for vehicles of Classes G, H, I and J, and a minimum width of 20 centimetres for vehicles of Classes A to F.

In those cases where the mudguards are entirely or partly overhung by the structure of the body, the combination of mudguards and body or the body alone must nevertheless fulfil the above-mentioned requirement as to protection.

The rear extremities of the front wings must not be higher from the ground than a horizontal line passing through the centre of the front wheel hub cap.

249. Hoods. — When a hood is required by the supplementary regulations, it must effectively protect all the available seats of the car. The rear panel of the hood must be closed and free from opening. For all cars carrying more than one seat the minimum width of the rear panel of the hood shall not be less than 80 centimetres.

In the case of cars in Classes G, H, I, J which are only required to carry one seat, the minimum width of the rear panel of the hood shall be 40 centimetres.

The minimum height for the whole of the hood of all cars shall be 80 centimetres above the highest point of each seat on which no one is sitting nor any pressure shall be used during measurement.

N. B. — During races the hoods may be in the raised or in the lowered position, according as the supplementary regulations may require.

250. Starting. — An automatic engine starter in proper working order is obligatory except for Classes I and J. Supplementary regulations may stipulate that no other form of starting shall be allowed.

251. Warning Apparatus, Rear-Reflecting Mirrors, Silencers. — Vehicles shall be provided with :

1. Warning apparatus as required by the road regulations of the country in which the race is run ;

2. A rear-reflecting mirror ;

3. An efficient silencer.

The efficiency of the silencer is thus defined and tested :

The exhaust shall give the impression of a muffled and diminishing noise, in which the explosions of each cylinder are not strongly accentuated.

252. **Spare wheel.** — One spare wheel fitted with tyre, placed outside the space reserved for passengers.

253. **Lighting.** — Lighting in proper working order and in accordance with the road regulations of the country in which the race is run.

254. **General Conditions.** — All equipment or accessories required in Art. 2 must be maintained (or if necessary replaced by repair) in their normal position until the end of the competition under penalty of being stopped and excluded from the competition.